

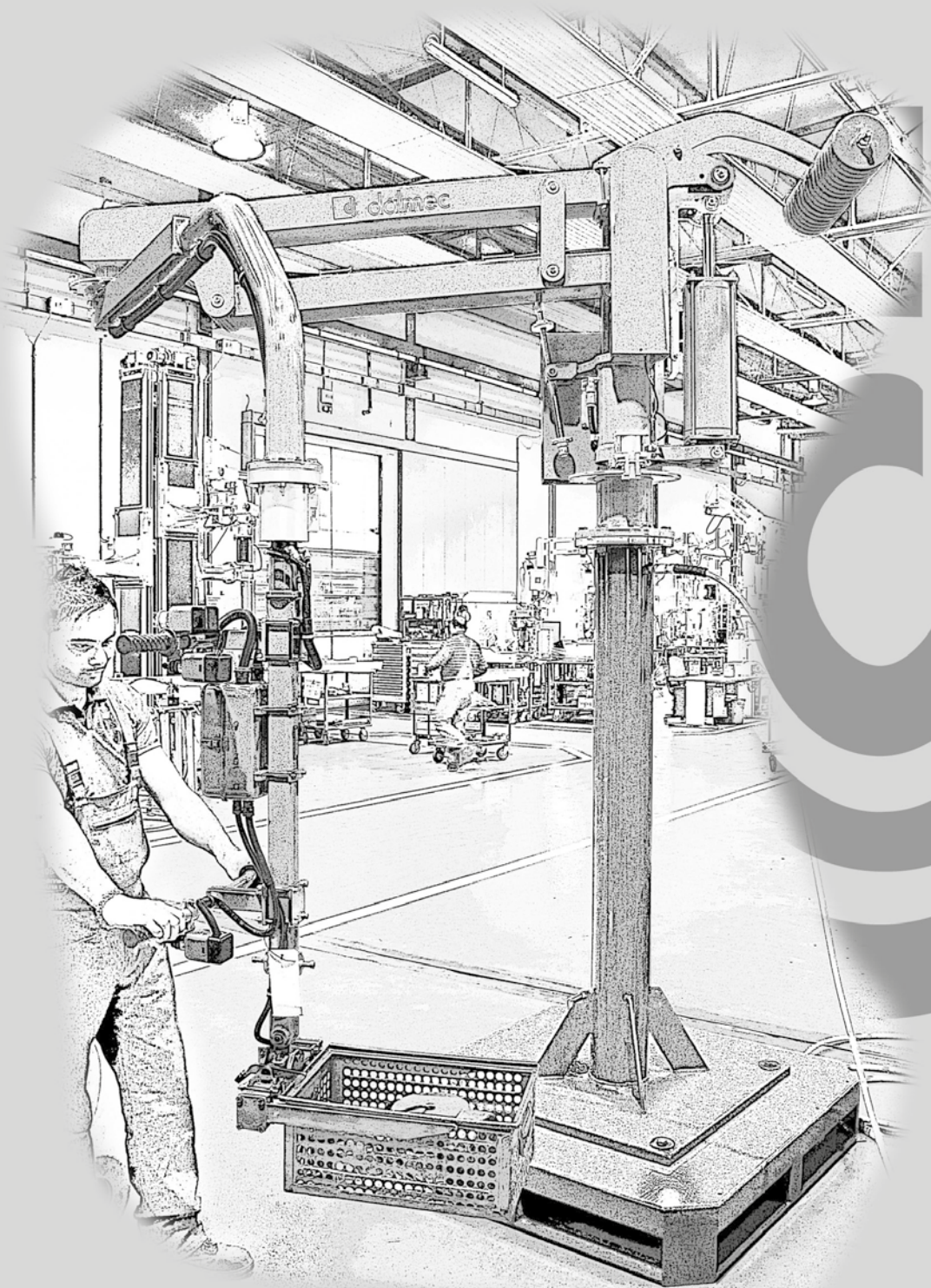

dalmec

1749769

POPULAR INK



INSTRUCTION MANUAL



ORIGINAL INSTRUCTION

MANUFACTURER

Dalmeccan S.p.A.

Via Gramsci, 2 - C.P. 104

38023 CLES (TN) - I

Tel: (0039) 0463-675111

Fax: (0039) 0463-421380 - 424450

dalmeccan@dalmeccan.it

BRANCH OFFICE

Dalmeccan Inc.

469 Fox Ct.

Bloomington

ILLINOIS 60108

Tel: 630-307-8426

Fax: 630-307-8436

service@dalmeccanusa.com

IDENTIFICATION DATA

Type PEC

Serial No. 1749769

Construction year 2017

Manual printed in Cles on 28/02/2017



Contents

1 RULES AND GENERAL WARNING

1.1	WARNINGS	8
1.2	INTRODUCTION	9
1.3	INFORMATION ABOUT THE MANUAL	9
1.4	USE OF ICONS	9
1.5	MEANING OF SYMBOLS	10
1.6	QUALIFICATION OF THE OPERATORS ASSIGNED TO THE MANIPULATOR	11
1.7	INDIVIDUAL PROTECTIVE DEVICES	12
1.8	SERVICE	12
1.9	SPARE PART ORDER	12
1.10	MAIN NORMATIVE REFERENCES	13

2 GENERAL DESCRIPTION AND TECHNICAL DATA

2.1	GENERAL DESCRIPTION OF THE MANIPULATOR	16
2.2	USE	16
2.3	OPERATING PRINCIPLE	16
2.4	LIFE TIME	16
2.5	EQUIPMENT ASSEMBLY DRAWING	17
2.6	TECHNICAL DATA	18
2.6.1	Mechanical specifications	18
2.6.2	Pneumatic specifications	18
2.6.3	Electric specifications	18
2.6.4	Aerial noise and vibration	18
2.6.5	Operating environmental conditions	18
2.7	MARKING AND IDENTIFICATION	19
2.8	RESIDUAL EXHAUST	19
2.9	DEMOLITION OF THE MANIPULATOR	19

3 TRANSPORT AND INSTALLATION

3.1	PACKING	22
3.2	TRANSPORT	22
3.3	STORAGE	22
3.4	INSTALLATION	23
3.4.1	Fixing	23
3.4.2	Air connection	23
3.4.3	Rod reaction	23

4 ADJUSTMENT AND OPERATING INSTRUCTIONS

4.1	PNEUMATIC ADJUSTMENTS	26
4.1.1	Supply pressure	26
4.1.2	No-load balancing	26
4.1.3	Load balancing	26
4.1.4	Inclination speed	26
4.1.5	Mandrel expanding speed	26
4.1.6	Mandrel expanding pressure/force	26
4.1.7	Preselector's reference stops	27
4.2	MECHANICAL ADJUSTMENTS	28
4.2.1	Horizontal drift	28
4.2.2	Vertical excursion	28
4.2.3	Angular delimiters	29
4.2.4	Joints brakes closing force	29

4.3	OPERATING INSTRUCTIONS	30
4.3.1	Working cycle	30
4.3.2	Parking position	31
4.3.3	Cycle counter	31
4.3.4	Variation of locating plate position	31
5 RISK ASSESSMENT		
5.1	RISKS ASSESSMENT	34
5.1.1	Hazards analysis	34
5.1.2	List of the requirements, risks, rules and adopted solutions	37
6 SAFETY		
6.1	SAFETY DEVICES	42
6.1.1	Non-return valve	42
6.1.2	Safety valve	42
6.1.3	Pneumatic reservoir	42
6.1.4	Anti-release	43
6.1.5	Piloted non-return valve	43
7 MAINTENANCE AND TROUBLESHOOTING		
7.1	ROUTINE MAINTENANCE	46
7.2	SCHEDULED MAINTENANCE	48
7.3	SPECIAL MAINTENANCE	49
7.4	TROUBLESHOOTING	50
7.4.1	Pneumatic relay	52
7.5	CHECK REGISTERS	53
8 DIAGRAMS		
8.1	PNEUMATIC DIAGRAM	56
8.2	LIST OF THE PNEUMATIC COMPONENTS	57
9 EC DECLARATION OF CONFORMITY		

- To avoid the incorrect and unpermitted use of the Manipulator, the instruction manual must always be used and within the operator's reach.

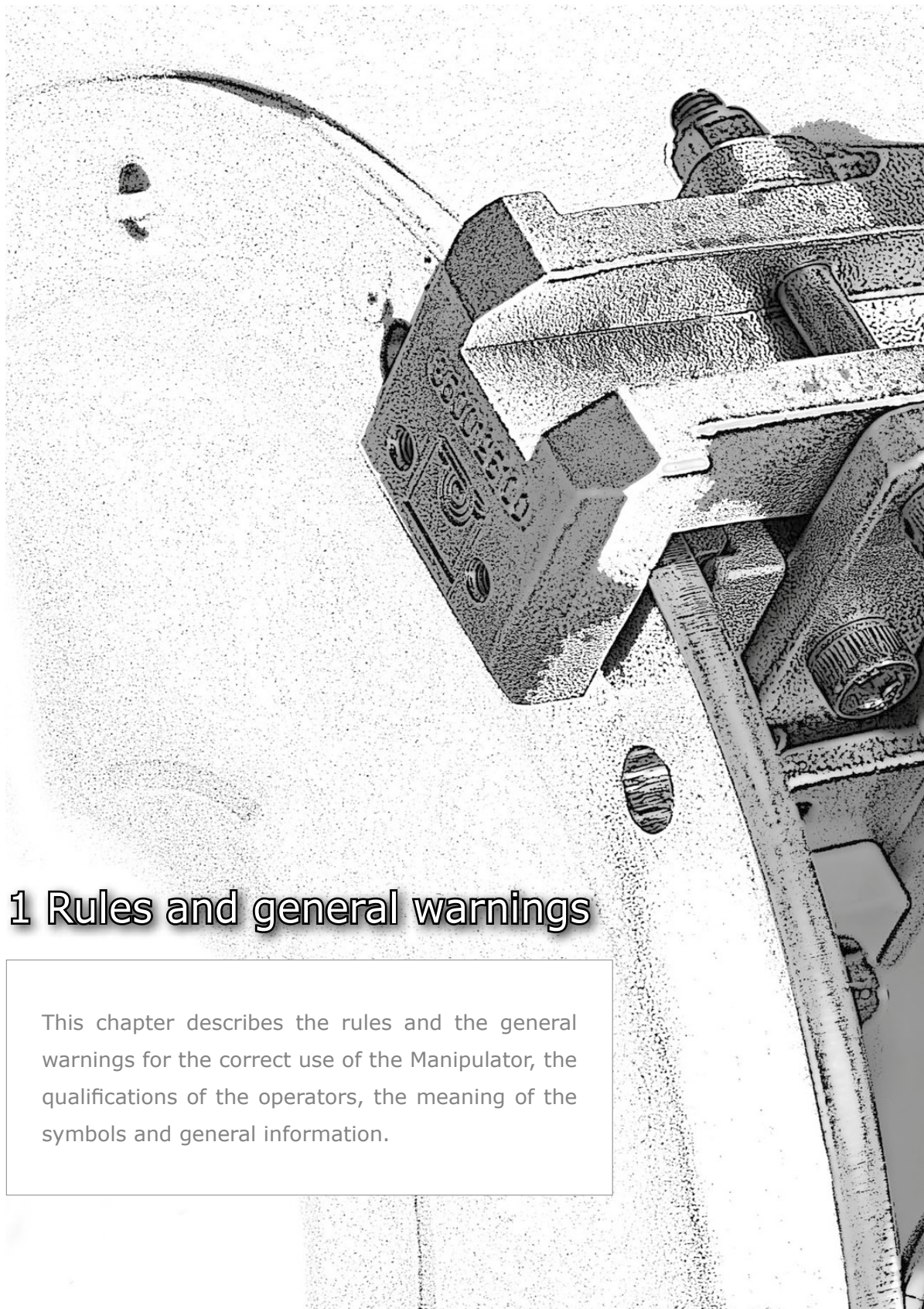

1 Rules and general warnings

This chapter describes the rules and the general warnings for the correct use of the Manipulator, the qualifications of the operators, the meaning of the symbols and general information.

1 RULES AND GENERAL WARNINGS

1.1 WARNINGS

- Do not use the Manipulator for the lifting or transport of persons and/or animals.
- The operator can use the Manipulator only after receiving precise instructions and a short training period.
- Do not manipulate loads over persons.
- Manipulate only the products defined by contract.
- Only authorized people should stay within the working area of the Manipulator.
- Do not apply loads heavier than the Manipulator max weight-capacity.
- If the Manipulator is mounted on a forkable baseplate, make sure that the support surface is flat and the baseplate touches the floor.
- When not in use bring the Manipulator to the parking position.
- Do not use the Manipulator if it is damaged and report any wear and operating problem.
- Do not use the Manipulator if there are defects or irregularities relating to safety and working.
- Only removable gripping equipment, manufactured in conformity with EN 13155:2003 + A2:2009 standard, can be applied under the Manipulator's hook.
- Never disassemble, reassemble or dismantle your Manipulator without the supervision of Dalmecc authorized technicians
- Make sure that the load is correctly positioned before releasing it.
- Use the Manipulator only as described in this manual.
- The operators must scrupulously follow what is reported in this manual and also adapt and observe the general accident prevention rules enforced by the EC directives and by the legislation of the nation they belong to.
- This manual must be complete and readable: every operator assigned to the use or maintenance of the Manipulator has to know where the manual is kept and must have the possibility to consult it whenever needed.
- It is severely forbidden to the customer/user or any third party to modify the Manipulator, its functions or the present manual in any way.

Texts, images, technical data and information contained in this manual are subject of intellectual property rights of Dalmecc SpA. It is forbidden to copy or reproduce it, even partly, except as is strictly necessary for the use and maintenance of the machine to which it is related to.

1.2 INTRODUCTION

This instruction manual is part of the Manipulator, therefore it must be kept for eventual future references until the dismantling of the Manipulator.

The user is requested to keep this manual near the Manipulator, in a dry place, sheltered from the sun's rays.

The instruction manual conforms with 2006/42/EC directives, enclosure I, 1.7.4. Should the manual be damaged or unreadable in any of its parts, please request Dalmec immediately for a replacement copy.

The personnel assigned to the use and the maintenance of the Manipulator as well as the personnel assigned to transport and assembly operations must read this instruction manual.

This document is a property of Dalmec and without its own written authorization it may not be imparted to third party or reproduced.

All rights reserved.

1.3 INFORMATION ABOUT THE MANUAL

All pneumatic parts (valves, push-buttons, safety devices) mounted on the Manipulator are numbered in order to make their identification easier. This numbering is reported in the pneumatic diagram.

The instruction manual is structured according to this numbering: the reference number reported in the manual indicates a component illustrated in the pneumatic diagram.

1.4 USE OF ICONS

In this instruction manual icons symbolize and identify types of operation, qualification of the operators, dangers, etc...

For example, if an operation, like maintenance, requires the intervention of an operator, an icon indicates the necessary qualification to perform it.

Icons and their meaning are listed in the following paragraphs.

Texts, images, technical data and information contained in this manual are subject of intellectual property rights of Dalmec SpA. It is forbidden to copy or reproduce it, even partly, except as is strictly necessary for the use and maintenance of the machine to which it is related to.

1.5 MEANING OF SYMBOLS

These symbols are used throughout the instruction manual in order to visually indicate hazard warnings.



This symbol appears next to all safety instructions. The non-observance to all instructions relating to safety may cause severe damages to the Manipulator and/or to the operator.



Contact with live parts can result in immediate death.

Protective covers marked with this sign may only be opened by specialists and/or instructed persons. Before opening the feed voltage must be disconnected.



Suspended loads: do not stop or transit near suspended load.



Risk of hands crushing: do not approach mechanical parts, that are moving or may start moving.



Risk of feet crushing: do not approach mechanical parts, that are moving or may start moving.



Do not handle the load, standing in front of the terminal arm.



Parts of the Manipulator may come into collision with the operator.



Do not insert the gripping control without the load to be handled.

1.6 QUALIFICATION OF THE OPERATORS ASSIGNED TO THE MANIPULATOR

The operator assigned to the use and maintenance of the Manipulator must have the specific professional qualifications for each operation to be performed. The operator must be trained and informed of the tasks assigned to him.

It follows a description of the professional qualifications of the operators assigned to the Manipulator.

The symbol next to the description show the qualification necessary to perform the operation described.

First level operator



NON - qualified personnel, without specific competences, who is able to carry out only simple tasks, as operating the Manipulator in normal conditions.

Second level operator



NON- qualified personnel, without specific competences, who is able to carry out the tasks assigned to the first level operator, as well as easy adjustments and setting up of the Manipulator.

Maintenance technician



Qualified technician who is able to carry out the tasks assigned to the first and second level operators, who is also able to operate on the mechanical and pneumatic parts in order to carry out adjustments, trouble shooting, maintenance and repair.

Dalmec technician



Person qualified by Dalmec to carry out complex operations.



Persons under the influence of drugs, alcohol or medicines which may affect their reactivity, must not operate, adjust or carry out maintenance operations on the Manipulator.

Texts, images, technical data and information contained in this manual are subject of intellectual property rights of Dalmec SpA. It is forbidden to copy or reproduce it, even partly, except as is strictly necessary for the use and maintenance of the machine to which it is related to.

1.7 INDIVIDUAL PROTECTIVE DEVICES

The operator and the technician must wear suitable working clothes and personal protective devices when using and carrying out maintenance of Manipulator.

Personal protective devices:

- safety shoes against the risk of fall of loads;
- safety gloves against the risk of abrasions or cutting one's hand (if necessary);
- safety glasses and masks against splinters, dust, fumes or exhalations (if necessary);
- auricular protections (ear plugs or earphones), if the acoustic pressure level in the working area is over 85 dB(A);
- helmet against the risk of collision with parts of the Manipulator (if necessary).

Working clothes

The operators must not wear loose clothing and jewellery (rings, bracelets, etc..) which may be caught up into the mechanism.

In case of long hair, suitable hairnets or caps must be worn to avoid being entangled.

1.8 SERVICE

In case of problems or situations, which requires the intervention of a qualified technician, please call our Service Department.

1.9 SPARE PART ORDER

If spare parts have to be ordered, please call Dalmec Spare Parts Office or our Service Department indicating the Manipulator's serial number written on the identification plate.

Only Dalmec spare parts are to be fitted, although section 7.2 lists original suppliers name and order code of pneumatic parts approved by Dalmec as an alternative.

1.10 MAIN NORMATIVE REFERENCES

Directive 2006/42/EC	Machinery directive
Directive 2014/34/EU	Atex directive
Directive 2014/30/EU	Electromagnetic compatibility
Directive 2014/35/EU	Low voltage
Directive 2014/68/EU	Pressure equipment
Standard EN ISO 12100:2010	Safety of machinery. General principles for design - Risk assessment and risk reduction
Standard EN 14238:2009	Cranes. Manually controlled load manipulating devices.
Standard EN ISO 13857:2008	Safety of machinery - Safety distances to prevent hazard zones being reached by upper and lower limbs.
Standard EN 349:2008	Safety of machinery. Minimum gaps to avoid crushing of parts of the human body.
Standard EN 1005-3:2009	Safety of machinery - Human physical performance - Part 3: Recommended force limits for machinery operation.
Standard CEI EN 60204-1:2006 (CEI 44-5)	Safety of machinery. Electrical equipment of machines. Part 1: General requirements.
Standard EN ISO 4414:2012	Pneumatic fluid power. General rules and safety requirements for systems and their components
Standard EN 953:2009	Safety of machinery. Guards. General requirements for the design and construction of fixed and movable guards.
Standard EN 14119:2013	Safety of machinery - Interlocking devices associated with guards - Principles for design and selection
Standard EN ISO 13850:2008	Safety of machinery. Emergency stop. Principles for design.
Standard EN 574:2008	Safety of machinery. Two-hand control devices. Functional aspects. Principles for design.
Standard EN ISO 4413:2012	Hydraulic fluid power - General rules and safety requirements for systems and their components
Standard EN 842:2009	Safety of machinery. Visual danger signals. General requirements, design and testing
Standard EN 1037:2008	Safety of machinery. Prevention of unexpected start-up.
Standard EN 614-2:2009	Safety of machinery - Ergonomic design principles - Part 2: Interactions between the design of machinery and work tasks
Standard ISO 8573-1:2010	Compressed air. Contaminants and purity classes.
Standard EN ISO 13849-1: 2008	Safety of machinery. Safety-related parts of control systems. Part 1: General principles for design
Standard EN 13463-1: 2009	Non-electrical equipment for potentially explosive atmospheres. Part 1. Basic method and requirements.
Standard EN 13463-5: 2011	Non-electrical equipment for potentially explosive atmospheres. Part 5. Protection by constructional safety "c".
Standard EN 1127-1: 2011	Explosive atmospheres — Explosion prevention and protection. Part 1: Basic concepts and methodology

Texts, images, technical data and information contained in this manual are subject of intellectual property rights of Dalmec SpA. It is forbidden to copy or reproduce it, even partly, except as is strictly necessary for the use and maintenance of the machine to which it is related to.

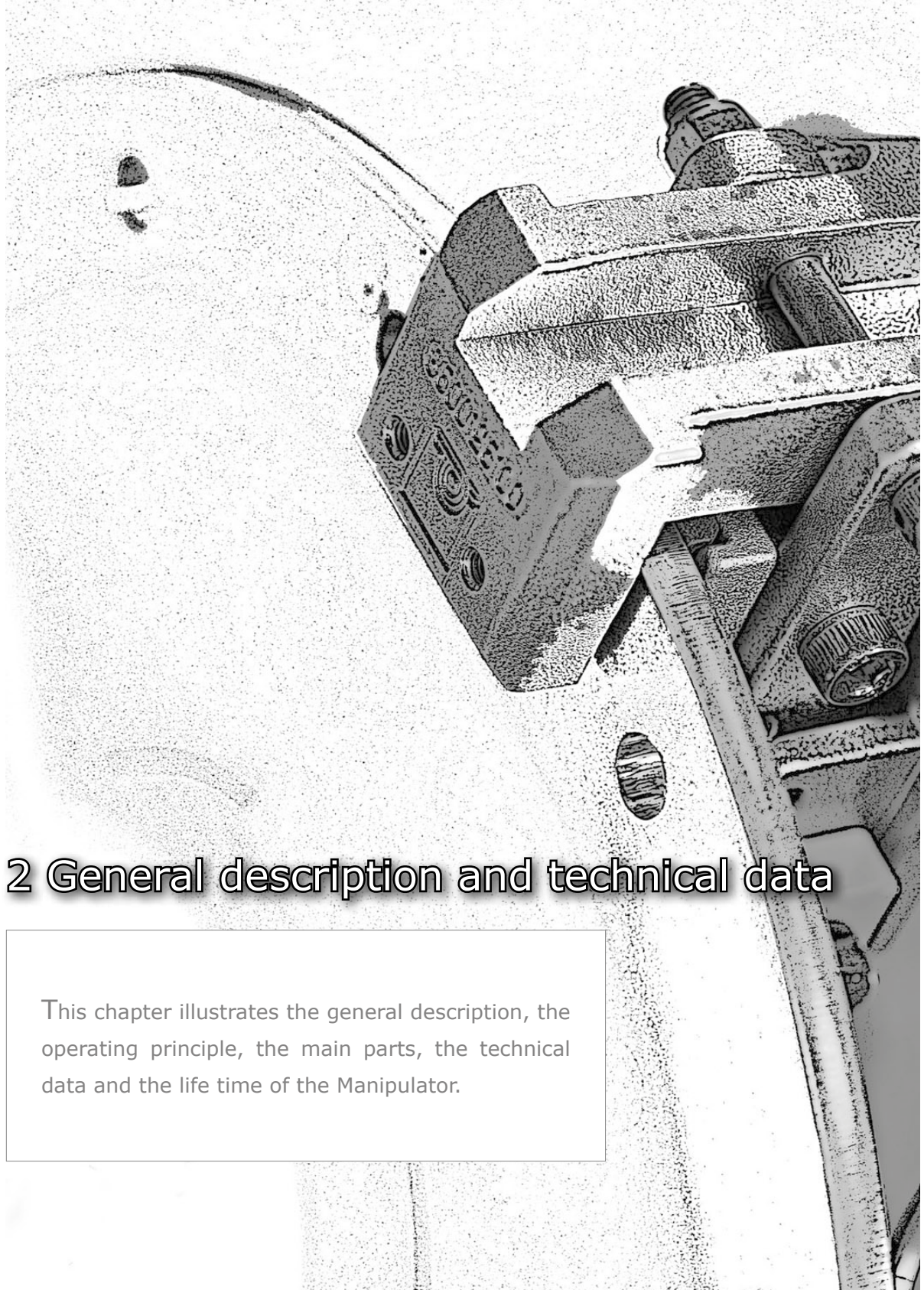

2 General description and technical data

This chapter illustrates the general description, the operating principle, the main parts, the technical data and the life time of the Manipulator.

2.1 GENERAL DESCRIPTION OF THE MANIPULATOR

The Manipulator is a pneumatically actioned lifting equipment, that allows to have a level change of the load being lifted. All the horizontal and vertical translations of the load in space, within the Manipulator action area, are free and obtained by a direct action of the operator on the gripping tool or on the load.

2.2 USE

The Manipulator is specially designed for quick and repetitive handling of reels.

The Manipulator is usable only by one operator at a time.



The Manipulator must be used only to handle the product for which it has been designed.

2.3 OPERATING PRINCIPLE

A pneumatic cylinder with a compressed-air feed, connected to a transmission system provides to lift the weight applied.

The cylinder force is controlled through two pneumatic circuits properly pre-set: the first one provides to always maintain in a balanced condition the gripping and transmission system weight; the second one provides to always maintain in a balanced condition the weight of the load.

2.4 LIFE TIME

The Manipulator structure has been designed for a theoretical resistance to fatigue and aging in the environmental conditions reported in the technical data and observing the operating and maintenance instruction in this manual.

The structural design does not take into account either the wear on parts or the commercial components.

- Register periodically the number of working cycles on the check register (section 7.5)
- A suitable planned maintenance schedule is a prerequisite requirement for the Manipulator life and its correct operation.
- Our Maintenance Service is at your disposal, at your own charge, for maintenance routines and periodic controls to verify the general conditions of the Manipulator.



The life time of the Manipulator is linked to the correct maintenance schedule and use.

2.5 EQUIPMENT ASSEMBLY DRAWING

The main parts of the Manipulator and their respective names are shown in the following figure.

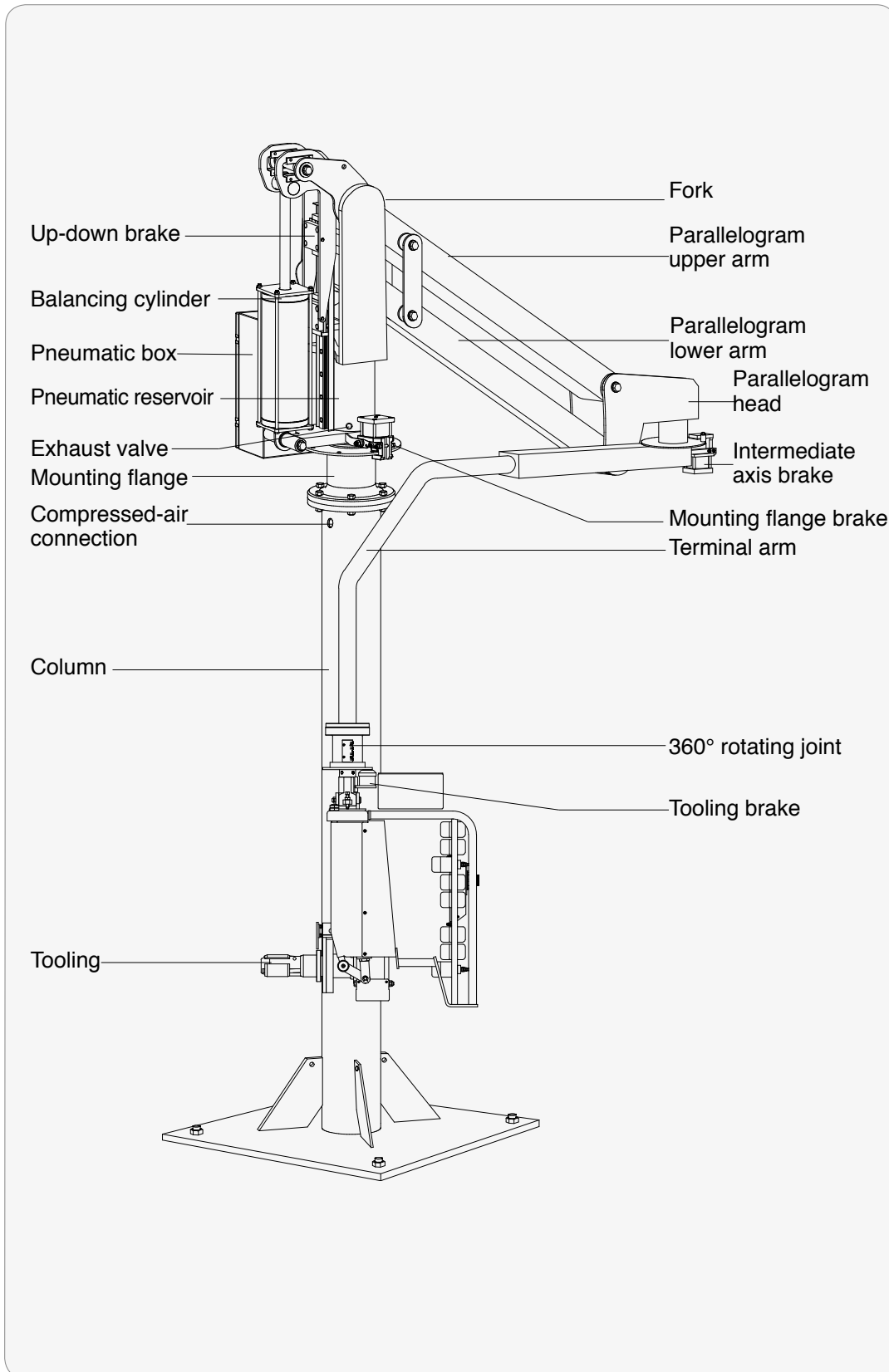

2.6 TECHNICAL DATA



Do not handle loads heavier than the indicated max weight capacity.

2.6.1 Mechanical specifications

Max weight-capacity	68 kg/150 lbs
Manipulator mass	658 kg
Max radius	2970 mm
Usable radius	2680 mm
Vertical lift	1300 mm
Rotation on the mounting flange axis	∞360°
Rotation on the intermediate axis	300°
Rotation on the tooling axis	∞360°

2.6.2 Pneumatic specifications

Supply fluid	Filtered (40 μm), oil-free (with max 1mg/m ³ of oil) and dry compressed air (dew point +3 °C). In conformity with the air quality degree 5,4,3 of the classification ISO 8573-1.
Supply pressure	0,9 MPa
Consumption "at rest"	5 NI/min
Max consumption per working cycle	193 NI
Ejector consumption	-
Pneumatic motor consumption	-

2.6.3 Electric specifications

Supply	-
Power	-
Protection	-
Explosion-proof	-

2.6.4 Aerial noise and vibration

Level of continuous acoustic pressure equivalent weighting A	<70 dB(A) Measured on a similar Manipulator with the phonometer at a distance of 1 mt from the Manipulator and at 1.60 mt from floor
Vibration hand-arm on the handgrip is less than 2.5 m/s ² .	

2.6.5 Operating environmental conditions

The Manipulator is assigned to operate inside protected sites, with the environmental conditions listed below.	
Temperature	+0° ÷ 45°C
Relative humidity	max 95%
Altitude	max 1500 m/asl
Atmosphere	Clean air, without abnormal quantities of dust, acid, corrosive gas, salt etc.

2.7 MARKING AND IDENTIFICATION

Each Manipulator is identified with a metallic plate mounted on the pneumatic box indicating the information about the CE mark.

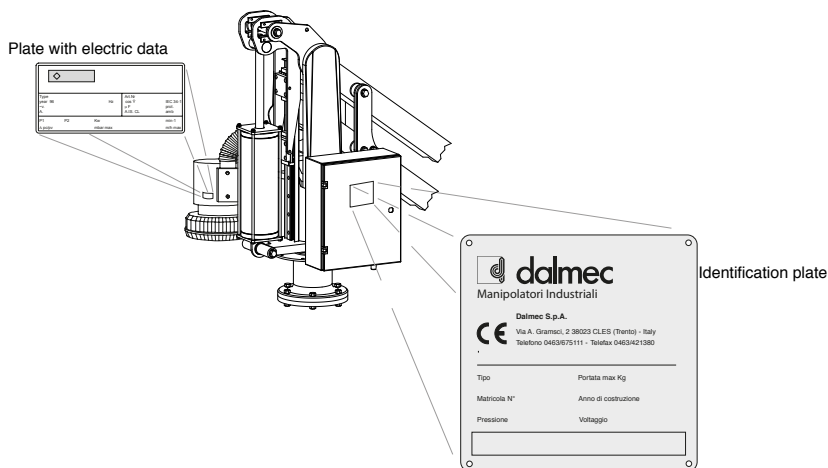

The electric specifications of a possible vacuum generator are indicated on a plate placed on the generator itself.

2.8 RESIDUAL EXHAUST

The Manipulator emits air in the environment with the same characteristics of the compressed-air used to supply it and periodically also water condensate.

2.9 DEMOLITION OF THE MANIPULATOR

If the Manipulator is no longer used, it is recommended to make it inoperative.

The materials used to manufacture the Manipulator are mainly ferrous. Besides there are also aluminium or alluminium alloys, which contain no more than 7.5% of magnesium, plastic and rubber materials.

The thickness of the paint of the Manipulator does not exceed the 0.2mm.

During the demolition of the Manipulator it is recommended to separate the above mentioned materials and to dispose of them according to the applicable regulations in force.

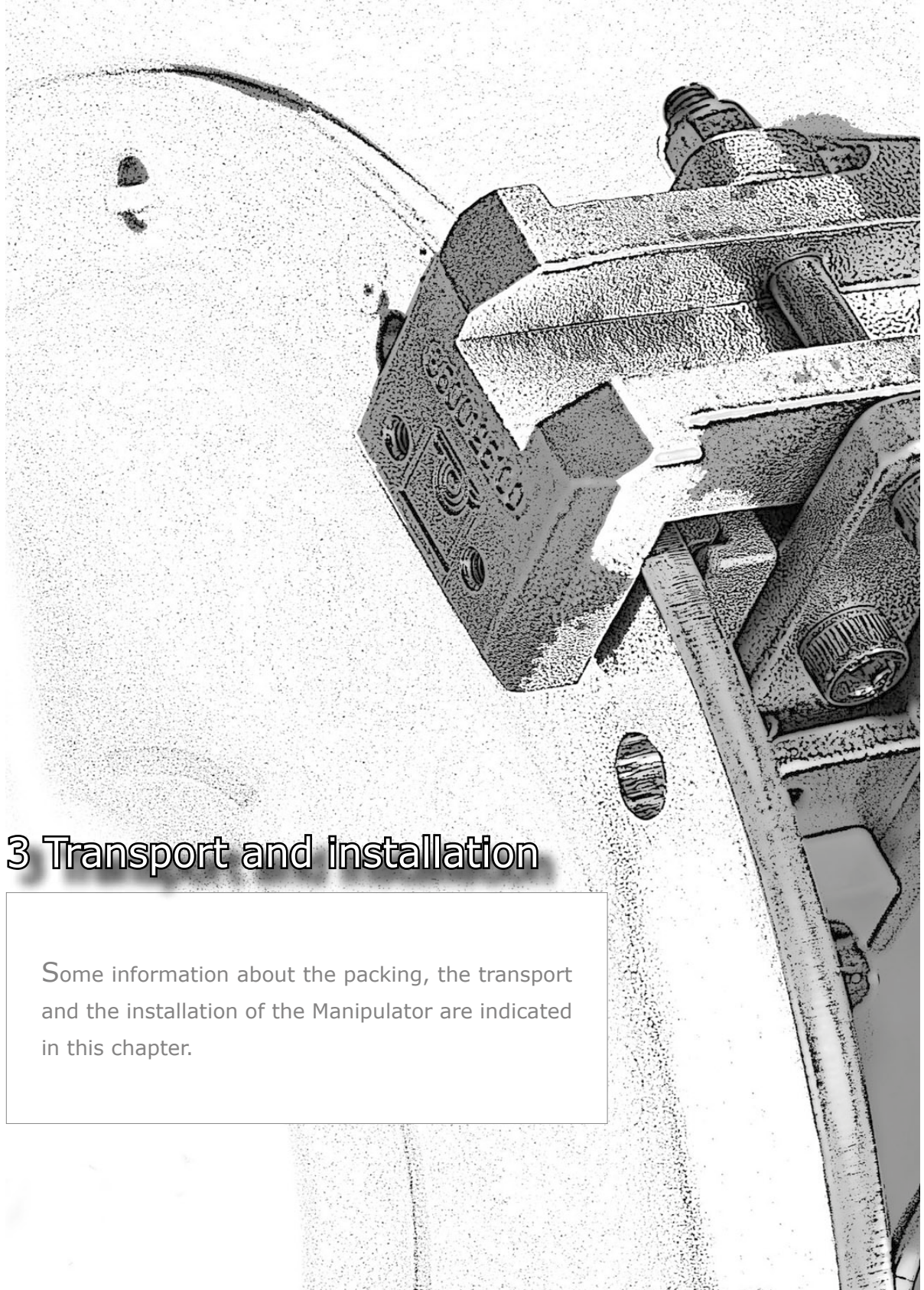

3 Transport and installation

Some information about the packing, the transport and the installation of the Manipulator are indicated in this chapter.

QUALIFICATION
3



Read carefully the warnings placed on the packing.

3.1 PACKING

The Manipulator is packed in a metallic or wooden crate, designed to hold and protect the Manipulator during transport.

Non painted metalsurfaces are covered with protective grease.

A plate positioned visibly on the packing indicates the net/gross weight and the instruction for the handling of the package.

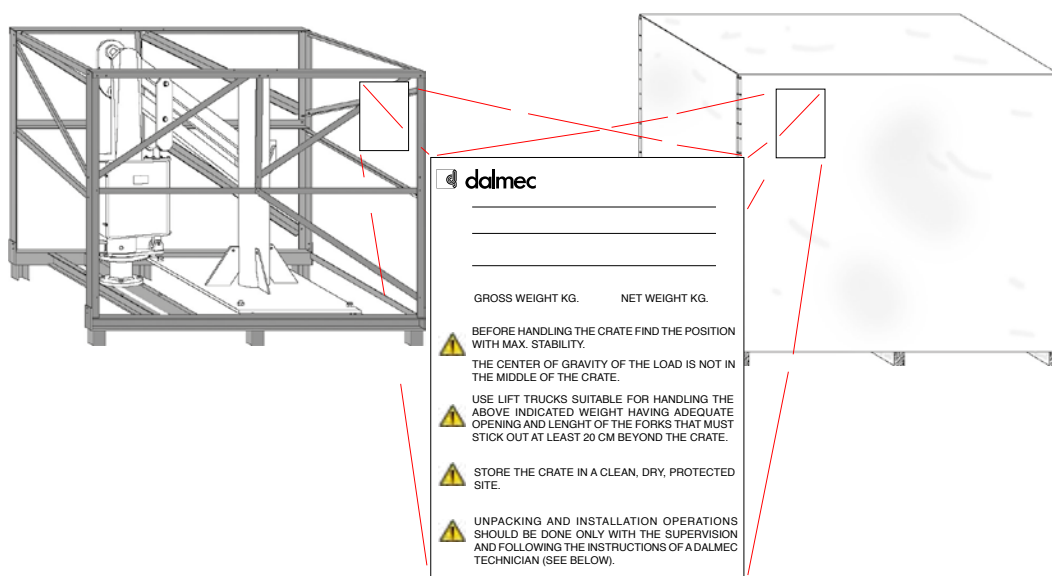

3.2 TRANSPORT

Handle the crate only with a lift truck suitable for handling the weight indicated on the plate, with adequate opening and length of the forks, which must remain at least 20 cm beyond the crate.



**BEFORE HANDLING THE CRATE FIND THE POSITION WITH MAX STABILITY.
THE CENTRE OF GRAVITY OF THE LOAD IS NOT IN THE MIDDLE OF THE CRATE.**

3.3 STORAGE

Store the crate in a clean, dry, dust-free protected place.

3.4 INSTALLATION

3.4.1 Fixing

The Manipulator is supplied with base-plate as shown in the picture.

Four bolts for holes $\text{Ø}25$ should be used to fix the base-plate to the floor.

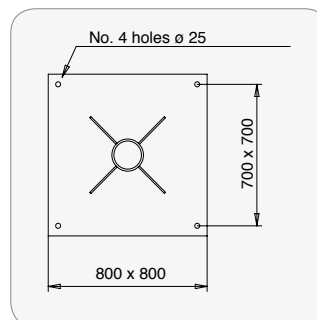

3.4.2 Air connection

The air connection, as shown in the figure, is positioned on top of the column.

The connection is made with a 3/8" NPT fitting.

The Manipulator should be fed with filtered (50 micron), dry and oil-free air with pressure and capacity as indicated in the technical data.

These instructions should be followed before carrying out the connection:

- exhaust the air supply tube before connecting it to the Manipulator
- adjust the regulator-filter group to the correct pressure (see adjustment instructions)
- when finished check that there is no loss in the circuit, which may result in malfunction of the Manipulator.

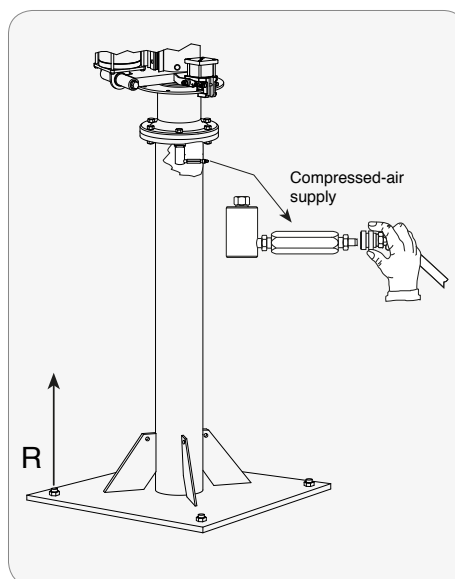

Disassemble, reassemble or dismantle the Manipulator only with the supervision of Dalmec authorized technicians.

3.4.3 Rod reaction

Rod reaction (R), due to the Manipulator mass and to the charge applied to it, is 3895 N on each rod.



If the Manipulator is mounted on a portable baseplate, make sure that the support surface is flat and that the baseplate touches the floor.

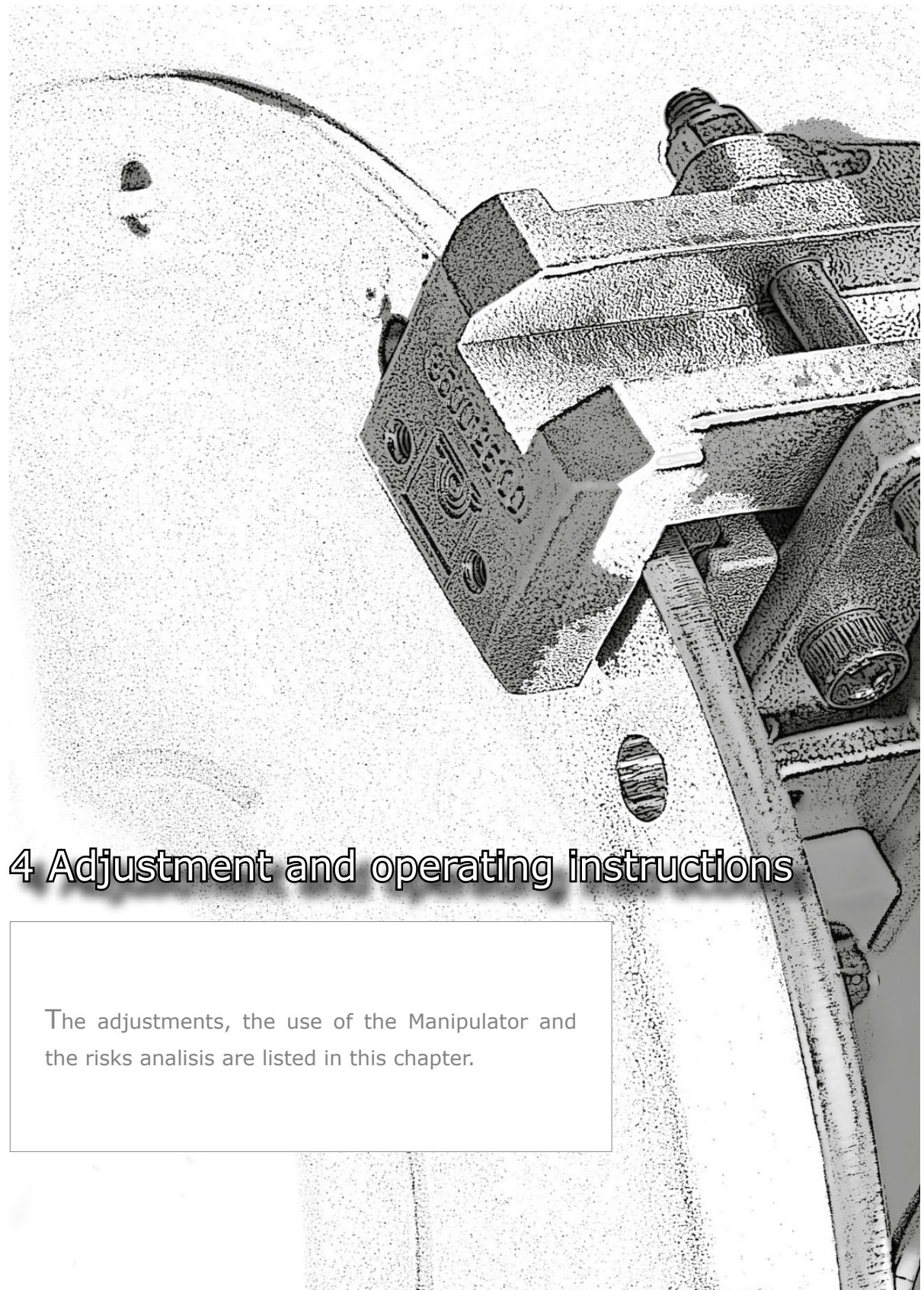

4 Adjustment and operating instructions

The adjustments, the use of the Manipulator and the risks analysis are listed in this chapter.

4 ADJUSTMENT AND OPERATING INSTRUCTIONS

QUALIFICATION

2



During test and inspection, your Manipulator has been finely adjusted.

However, if necessary, we list the main adjustments to be done on your Manipulator for its correct operating.

4.1 PNEUMATIC ADJUSTMENTS

4.1.1 Supply pressure

- Pull the knob of the regulator (No. 12) to release it and slowly turn it until the pressure gauge (No. 13) indicates 0.9 MPa. Push the knob to lock it.

NB The Manipulator supply pressure must be dry, filtered and oil-free.

4.1.2 No-load balancing

- Operate the lever (No. 25) to disengage the brakes of the Manipulator
- Pull the knob of the regulator (No. 11) to release it and slowly turn it until the tooling remains balanced. Push the knob to lock it.

4.1.3 Load balancing

- Operate the lever (No. 25) to disengage the brakes of the Manipulator
- Turn the regulator knob (No. 46) counterclockwise until it stops, or until the pressure gauge (No. 47) indicates 0 MPa
- Completely insert the mandrel in the inside core of the reel
- Push the buttons (No. 26-27 or 33-34) to grip the load, the optical indicator (No. 55) signals the gripping
- Slowly turn the regulator knob (No. 46) clockwise until the load remains balanced.

NB Should the load weight change, the load balancing adjustment must be repeated for every variation of weight.

4.1.4 Inclination speed

- Adjust the flow regulators (No. 58-59-61-62)

4.1.5 Mandrel expanding speed

- Adjust the flow regulator (No. 49)

4.1.6 Mandrel expanding pressure/force

- Pull the regulator knob (No. 24) and slowly turn it clockwise or counterclockwise to increase or decrease the mandrel expanding pressure. Push the knob to lock it.

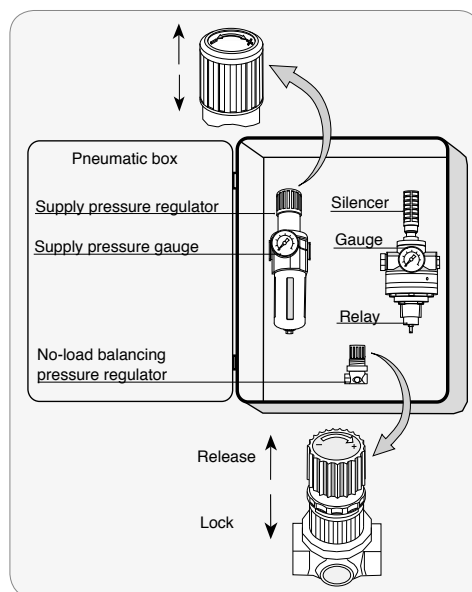

Reel max. length = 508 mm / 20 in

() The numbering refers to the component reported in the pneumatic diagram (see par. 8.1)

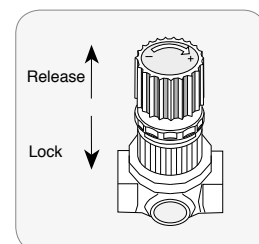

4.1.7 Preselector's reference stops

- Loosen the fixing screws using a 3 mm setscrew wrench
- Turn the preselector knob counterclockwise until it stops
- Grip the lower weight load
- Turn the preselector knob clockwise until the load remains balanced
- Place the reference stop (A) close to the position indicator (left)
- Position the load on its support point and release it
- Grip the heaviest load
- Turn the preselector knob clockwise until the load remains balanced
- Place the reference stop (B) close to the position indicator (right)
- Tighten the fixing screws.

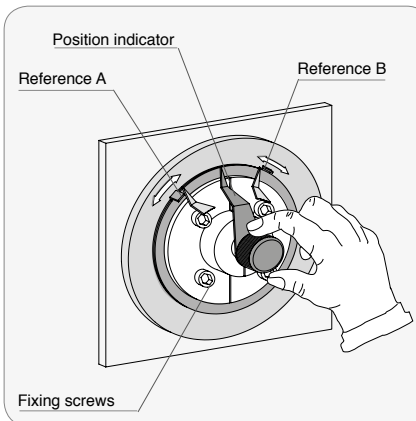

QUALIFICATION
3



QUALIFICATION
3



4.2 MECHANICAL ADJUSTMENTS

4.2.1 Horizontal drift

- Position a spirit level on the mounting flange to check the level (Pos. A)
- Remove the fork plastic covers
- Grip the load
- Bring the Manipulator to the max. radius position
- Brake the Manipulator
- Position the level on the bearing housing (Pos. B)
- With a 19 mm spanner adjust the screws of the leveling device positioned in both sides of the fork to level the bushing
- Avoid gaps between bracket and locating blocks.
- Disengage the Manipulator's brakes
- Check the handling of the Manipulator, in particular the horizontal drift of the load
- Remount the fork plastic covers

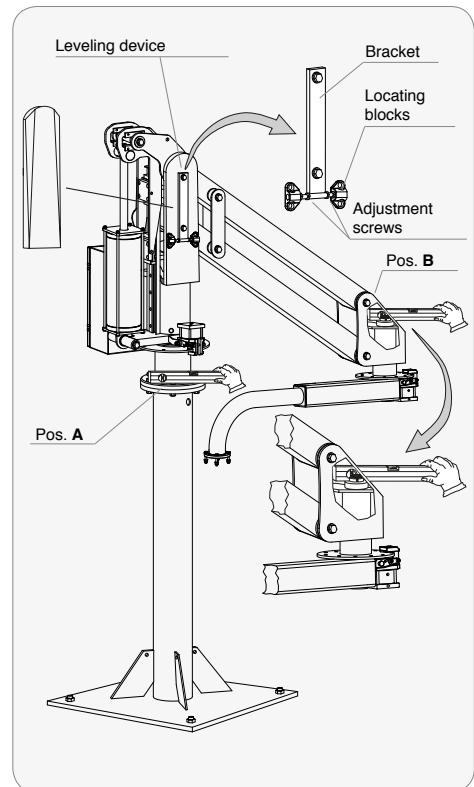

4.2.2 Vertical excursion

- To change the vertical excursion of the tooling, adjust the threaded rod's nuts/lock-nuts positioned on the balancing cylinder.
- Adjust the lower end of stroke to the max excursion avoiding the tooling to touch the floor.

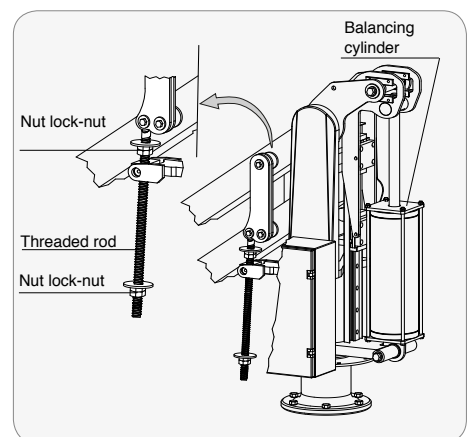

4.2.3 Angular delimiters

Column - intermediate axis

On the brake disks there are twelve equidistant holes. By removing or placing the delimiters into the holes you get the following adjustments:

No. of delimiters	Rotation	Attention
0	$\infty 360^\circ$	Make sure that there are no tubes or cables that may twist around the Manipulator
1	350°	
2	min. $0^\circ - 60^\circ$ to max. $0^\circ - 330^\circ$	

NB: Other holes can be made on the brake disk to obtain rotation angles different from the ones listed above.

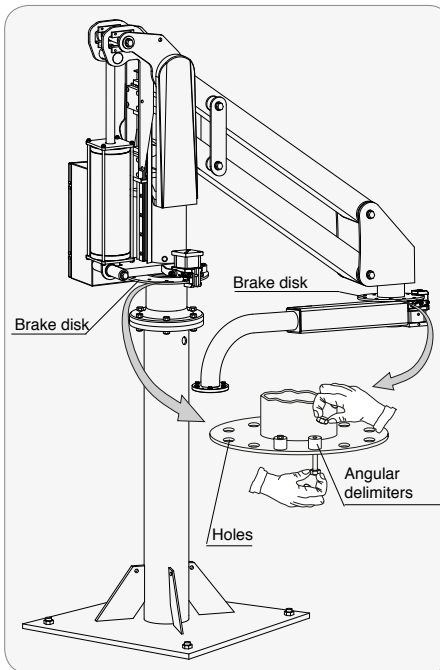

Tooling axis

If/when installed, it is possible to limit the rotation of the tooling by adjusting the position of the angular delimiters on the tooling swivel.

 The angular delimiters are a safety feature and must not be used as operational delimiters, as such misuse (wrong use) of their purpose may damage the manipulator.

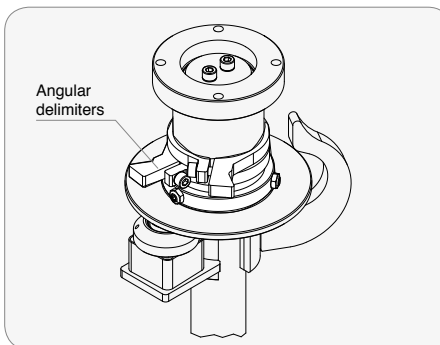

4.2.4 Joints brakes closing force

- Supply the Manipulator.
- Using a 3/16" hex. key unscrew the covering dowel positioned on the back of the brake unit.
- Using a 6 mm spanner unscrew the adjustment screw to bring the brake linings/pad near the brake disc or screw it to distance them.
- The correct distance between disc and pads is from 1 to 1,5 mm.
- Reposition the covering dowel in its seat.

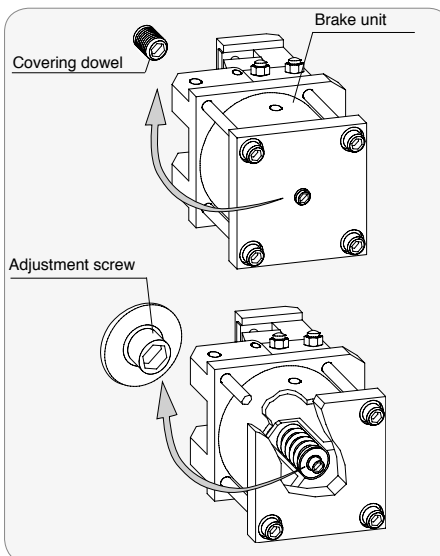

QUALIFICATION

2



Before releasing the load, make sure that it has been positioned in a correct and stable way.



Do not abandon the Manipulator after having gripped the load.



Only the assigned personnel can stay in the working area of the Manipulator.



Reel max. length = 508 mm / 20 in



Do not approach mechanical parts, that are moving or may start moving.

4.3 OPERATING INSTRUCTIONS

4.3.1 Working cycle

- Operate the lever (No. 25) to disengage the brakes of the Manipulator
 - Set the tooling for the gripping (see par. 4.3.4)
- NB Should the load weight change, repeat the load balancing adjustment (see par. 4.1.3)
- Completely insert the mandrel in the inside core of the reel
 - Push the buttons (No. 26-27 or 33-34) to grip the load, the optical indicator (No. 55) signals the gripping
 - Handle the load
 - Operate the lever (No. 52-64) to change the inclination of the load
 - Position the load on its support point
 - Push the buttons (No. 36-37 or 43-44) to release the load
 - Operate the lever (No. 25) to brake the Manipulator if you stop using it.

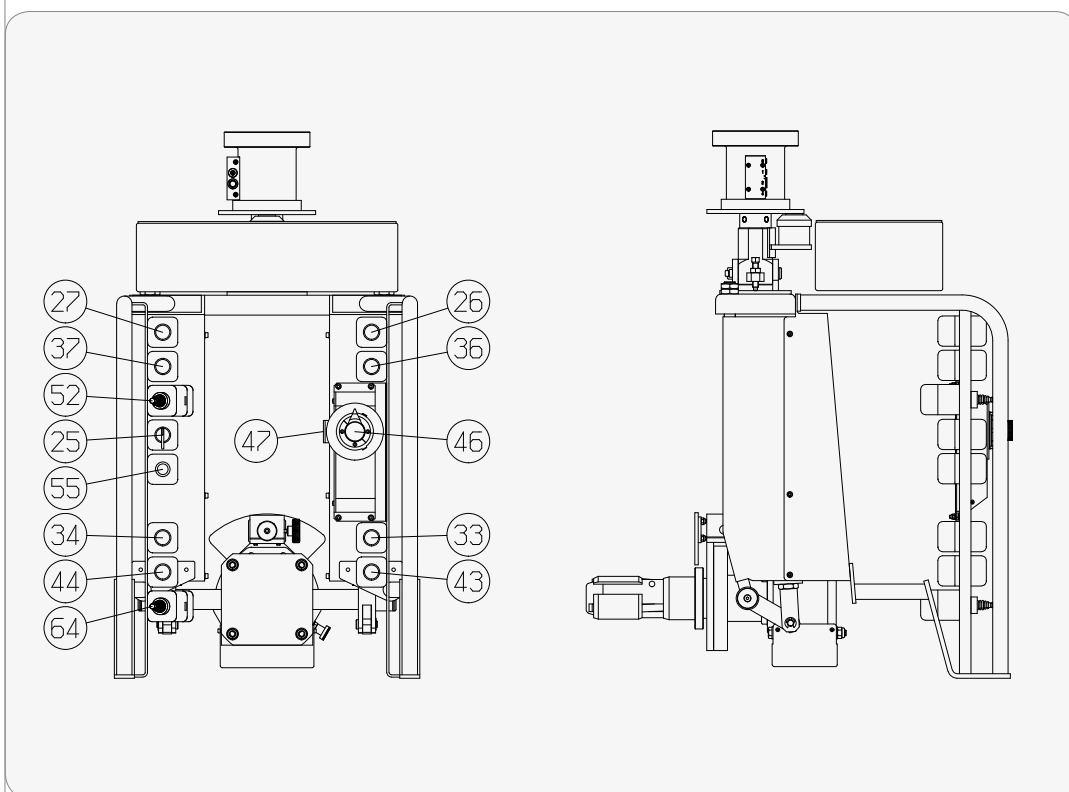

() The numbering refers to the component reported in the pneumatic diagram (see par. 8.1)



When not in use, bring the Manipulator to the parking position (see par.4.3.2).



In case of anomalies, damages, injury or block, bring the Manipulator to the parking position (see par. 4.3.2) and do not use it until the resolution of the problem.



Do not use the Manipulator if any defects or irregularities relating to safety and operating are detected.

4.3.2 Parking position

As illustrated in the figure, the Manipulator is in the parking position, when:

- no load is hooked
 - the vertical excursion is at the lower end
 - arms are bent at minimum radius
 - the articulation brake system is engaged.
- To avoid damaging your Manipulator or other nearby machinery or personnel, always bring the Manipulator to the parking position when it is not in use.

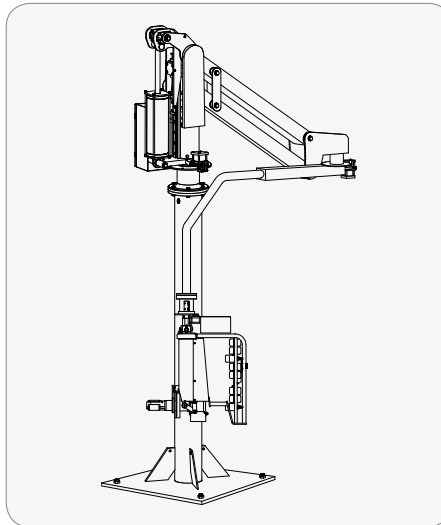

QUALIFICATION
2

**4.3.3 Cycle counter**

- Inside the pneumatic box there is a counter which counts the working cycles (see par. 7.5).

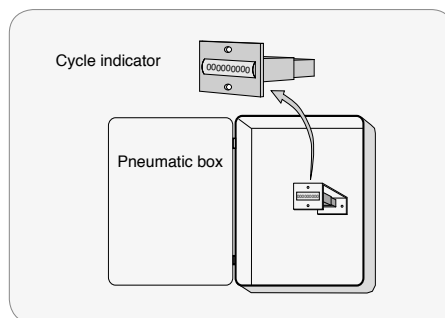
**4.3.4 Variation of locating plate position**

- Turn the knob counterclockwise to release the locating plate
 - Change the position of the locating plate
 - Turn the knob clockwise to block it.
- Make sure that the locating plate is blocked

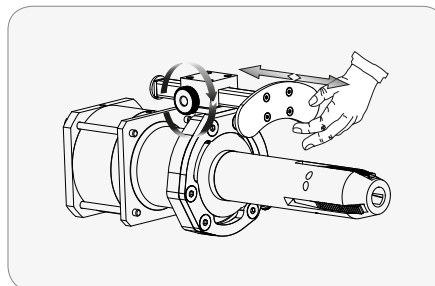

() The numbering refers to the component reported in the pneumatic diagram (see par. 8.1)

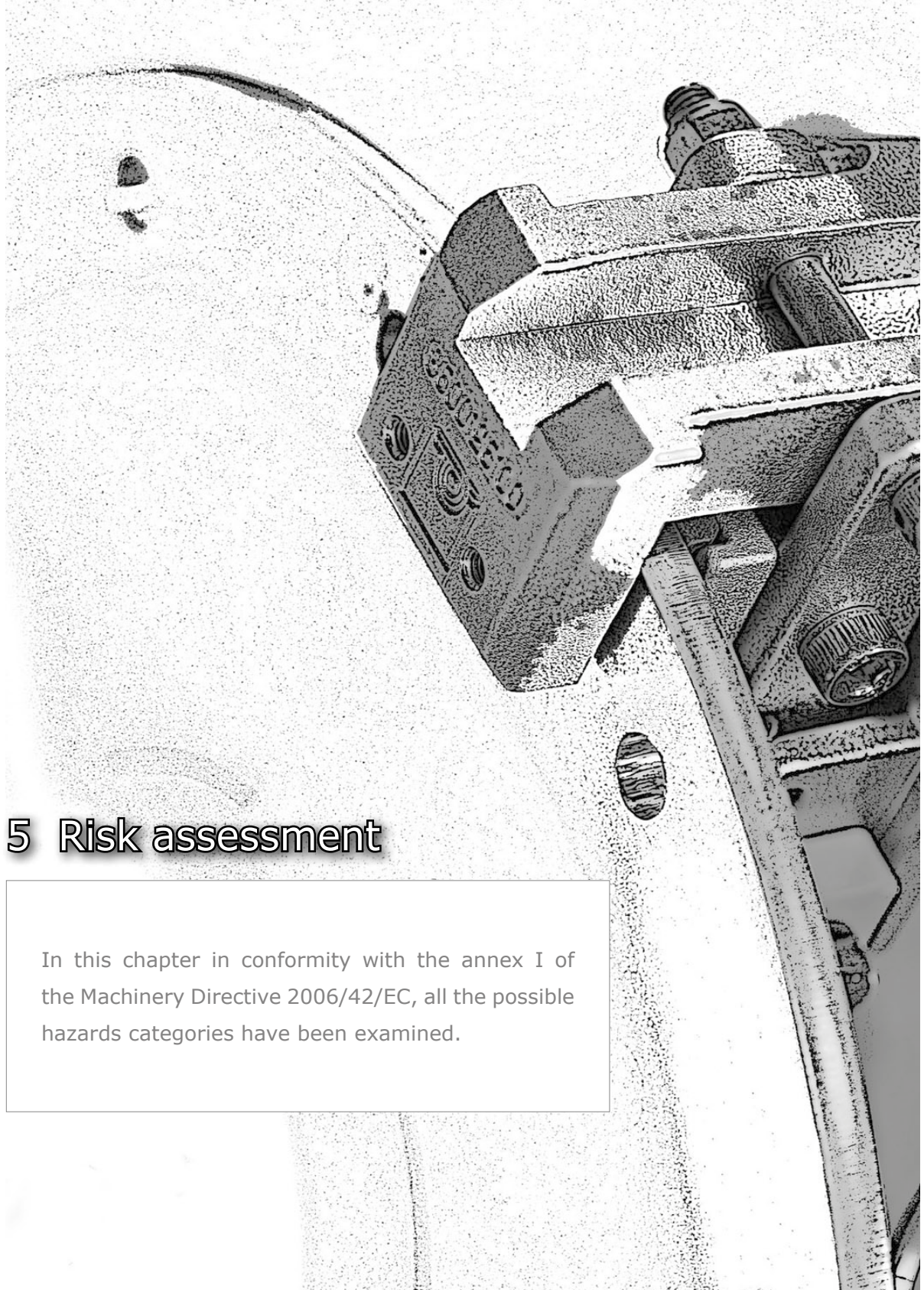

5 Risk assessment

In this chapter in conformity with the annex I of the Machinery Directive 2006/42/EC, all the possible hazards categories have been examined.





Identification of the hazards					
No.	Hazards	Potential consequences	Ann.1	EN 12100	Areas
4	Noise hazards: - Cavitation phenomena - Exhausting system - Gas leaking at high speed - Manufacturing process (stamping, cutting, etc.) - Moving parts - Scraping surfaces - Unbalanced rotating parts - Whistling pneumatics - Worn parts	- Discomfort - Loss of awareness - Loss of balance - Permanent hearing loss - Stress - Tinnitus - Tiredness - Any other (e.g. mechanical, electrical) as a consequence of an interference with speech communication or with acoustic signals	1.5.8	6.2.2.2 6.2.3 c) 6.2.4 c) 6.2.8 c) 6.3.1 6.3.2.1 b) 6.3.2.5.1 6.3.3.2.1 6.3.4.2 6.4.3 6.4.5.1 b) e c)	Working area
5	Vibration hazards: - Cavitation phenomena - Misalignment of moving parts - Mobile equipment - Scraping surfaces - Unbalanced rotating parts - Vibrating equipment - Worn parts	- Discomfort - Low-back morbidity - Neurological disorder - Osteo-articular disorder - Trauma of the spine - Vascular disorder	1.5.9	6.2.2.2 6.2.3 c) 6.2.8 c) 6.3.3.2.1 6.3.4.3 6.4.5.1 c)	Working area
6	Material/ substance hazards: - Aerosol - Biological and microbiological (viral or bacterial) agent - Combustible - Dust - Explosive - Fibre - Flammable - Fluid - Fume - Gas - Mist - Oxidizer	- Breathing difficulties, suffocation - Cancer - Corrosion - Effects on reproductive capability - Explosion - Fire - Infection - Mutation - Poisoning - Sensitization	1.1.3 1.5.6 1.5.7 1.5.13	6.2.2.2 6.2.3 b) 6.2.3 c) 6.2.4 a) 6.2.4 b) 6.3.1 6.3.3.2.1 6.3.4.4 6.4.5.1 c) 6.4.5.1 g)	
7	Ergonomic hazards: - Access - Design or location of indicators and visual displays units - Design, location or identification of control devices - Effort - Flicker, dazzling, shadow, stroboscopic effect - Local lighting - Mental overload/underload - Posture - Repetitive activity - Visibility - Inadequate consideration of the anatomy of the hand / arm or foot / leg	- Discomfort - Fatigue - Musculoskeletal disorder - Stress - Any other (e.g. mechanical, electrical) as a consequence of human error	1.1.2 1.1.4 1.1.5 1.1.6 1.2.1 1.2.2 1.7.1 4.1.2.7	6.2.2.1 6.2.7 6.2.8 6.2.11.8 6.3.2.1 6.3.3.2.1	Gripping and release area
8	Hazards associated with environment in which the machine is used - Dust and fog - Electromagnetic disturbance - Lightning - Moisture - Pollution - Snow - Temperature - Water - Wind	- Burn - Slight disease - Slipping, falling - Suffocation - Any other as a consequence of the effect caused by the sources of the hazards on the machine.	1.5.16	6.2.6 6.2.11.11 6.3.2.1 6.4.5.1 b)	Working area

Identification of the hazards					
No.	Hazards	Potential consequences	Ann.1	EN 12100	Areas
9	<p>Hazards generated by the absence (temporary) and/or by the wrong positioning of the measure/instruments regarding the safety.:</p> <ul style="list-style-type: none"> - All the types of shelters - All the devices (of protection) regarding the safety - Starting and stopping devices - Graphic signs and safety signals - All the information or warning devices - Devices for energy disengagement - Emergency devices 	<ul style="list-style-type: none"> - Being run over - Being thrown - Crushing - Cutting or severing - Drawing-in or trapping - Entanglement - Friction or abrasion - Impact - Injection - Shearing - Slipping, tripping and falling - Stabbing or puncture - Suffocation 	<ul style="list-style-type: none"> 1.1.2 1.2 1.3.7 1.3.8 1.4 1.7.1 1.7.2 1.7.3 	<ul style="list-style-type: none"> 6.2.8 f) 6.2.8 g) 6.2.11 6.2.12.2 6.2.13 6.3.2 6.3.3 6.3.4 6.3.5 6.3.5.2 6.3.5.4 6.3.5.5 6.4 7.2 	<ul style="list-style-type: none"> Gripping and release area Working area
10	<p>Other hazards:</p> <ul style="list-style-type: none"> - Non-use of personal protective measures - Insufficient information to the driver/operator - Human error, human behaviour - Uncontreeled load, overload, overrun of the overturning threshold - Fault of the energy power, (of the power supply circuit and/or of the control system) - Resetting of the power supply after interruption - Failure to stop the machine - Running in a track system - Breakage, malfunction of the control system (unexpected release) - Falling or ejection of objects or fluids - Abnormal conditions of assembly/test/use/maintenance - Insufficient mechanical strength of parts - Poor design of pulleys and drums - Unsuitable choice/integration in the machine of chains, ropes, lifting accessories - Maintenance - Use information 	<ul style="list-style-type: none"> - Being run over - Being thrown - Crushing - Cutting or severing - Drawing-in or trapping - Entanglement - Friction or abrasion - Impact - Injection - Shearing - Slipping, tripping and falling - Stabbing or puncture - Suffocation 	<ul style="list-style-type: none"> 1.1.2 1.2.1 1.2.2 1.2.3 1.2.4 1.2.5 1.2.6 1.3.3 1.5.4 1.6 4.1.2.2 4.1.2.3 4.1.2.4 4.1.2.5 	<ul style="list-style-type: none"> 6.2.3 a) 6.2.3 b) 6.2.8 f) 6.2.10 6.2.11 6.2.11.4 6.2.11.5 6.2.11.2 6.3.2.6 6.3.2.7 6.4.1 6.4.2 6.4.3 6.4.4 6.4.5 	<ul style="list-style-type: none"> Gripping and release area Working area



5.1.2 List of the requirements, risks, rules and adopted solutions

From the analysis of the hazards that are potentially present, the following safety requirements have been found, listed and codified according to the numeration indicated in the Machinery Directive, together with the directions of the applied rules and the adopted solutions.

Code	Requirements	Applied rules	Adopted solutions	Residual risk	Pictograms	
					Manual	Manipulator
1.1.1	Definitions	EN ISO 12100 EN 14238				
1.1.2	Principals of safety integration	EN ISO 12100 EN 14238	During design some measures have been taken in order to avoid the risks related to the described hazards.			
1.1.3	Materials and products	EN ISO 12100 EN 14238	The materials used do not involve any risk for the safety and the health of the persons.			
1.1.5	Design of machinery to facilitate its handling	EN ISO 12100 EN 14238	A special packaging which reports the instructions to lift the machine has been prearranged.	Possible overturn		
1.1.6	Ergonomics	EN ISO 12100 EN 14238	During design of the machine all elements have been taken into consideration in order to reduce mental or physical stress and the effort of the operator.			
1.1.7	Operating positions	EN ISO 12100 EN 14238	The machine does not send out exhaust emissions, does not need of a cab and does not generate a dangerous environment.			
1.2.1	Safety and reliability of control systems	EN ISO 12100 EN ISO 13849	The control systems mounted on the manipulator comply with the standard ISO 13849-1: 2008 Category 1 PL c. The controls are positioned on the gripping tooling.			
1.2.2	Control devices	EN ISO 12100 EN 14238	The control devices are visible and easily identifiable. The operator is able to ensure the absence of people in the working area of the Manipulator.			
1.2.3	Starting	EN ISO 12100	Follow the instructions in the user manual. The manipulator is controlled by the operator and it does not have parts that move independently. You have to disengage the brakes to use the Manipulator.			
1.2.4	Stopping	EN ISO 12100 EN 14238	The machine is equipped with brakes (operated by a lever) to lock the articulations.			
1.2.4.1	Normal stop	EN ISO 12100	The machine is equipped with brakes to lock the articulations. As stated in the manual, the Manipulator must not be left with the load during gripping and the stop device inserted.	Possible load fall		
1.2.4.3	Emergency stop	EN ISO 12100	The emergency stop corresponds to the normal stop because it would not reduce the stop time.			
1.2.6	Failure of the power supply	EN ISO 12100 EN 14238	The machine is equipped with an air reservoir that allows to terminate the operation in progress. Once the air reservoir has exhausted the compressed-air, the Manipulator slowly positions itself to the lower end of stroke. The kinematic motion does not allow to release the load, because of irreversible type.	Possible crushing		
1.3.1	Risk of loss of stability	EN ISO 12100	Together with the machine, we supply data regarding loads for a right dimensioning of the rods.			
1.3.2	Risk of break-up during operation	EN ISO 12100 EN 14238	The dimensioning in conformity with the rules in force of all the parts of the machine and the choice of the materials according to the use reduce to the minimum the brake-down risk during operation. Wear parts, periodical check and/or replacement are described in the Instruction Manual.			
1.3.3	Risks due to falling or ejected objects	EN ISO 12100 EN 14238	The risk of object fall is linked to the gripping-release operation. For the gripping operation, make sure that the mandrel has been correctly inserted into the bobbin, as described in the Instruction Manual. For the release operation, the operator must be sure that the load has been correctly and stably positioned on the releasing point.	Possible crushing		

Code	Requirements	Applied rules	Adopted solutions	Residual risk	Pictograms	
					Manual	Manipulator
1.3.3a	Risks due to the handling of products that do not conform	EN ISO 12100 EN 953 EN 13857 EN 349	The Manipulator is designed and dimensioned for the handling of specific products. A warning, indicating the max dimensions of the bobbin to be handled, has been placed on the gripping tooling.	Possible loss of load		
1.3.4	Risks due to surfaces, edges or angles	EN ISO 12100 EN 14238	Where possible, the edges have been rounded off.			
1.3.7	Risks related to moving parts	EN ISO 12100 EN 953 EN 13857 EN 349	The gripping - release controls are bimanual and compel the operator to keep both hands on the handgrips. Where possible, the mobile elements are equipped with shelters and guard devices.			
1.3.7a	Risks related to moving parts	EN ISO 12100 EN 953 EN 13857 EN 349	The normal use of the manipulator compels the operator to stand in front of the gripping tooling. The lower limbs do not come into contact with moving elements.			
1.3.8	Choice of protection against risks arising from moving parts	EN ISO 12100 EN 953 EN 13857 EN 349	The shelters and the guard devices are designed according to the risk type.			
1.3.9	Risks of uncontrolled movements	EN ISO 12100 EN 953 EN 13857 EN 349	The machine is equipped with stopping brakes or antidrift chain. Moreover we supply instructions for the correct parking of the machine when it is not in use.			
1.4.1	General requirements	EN ISO 12100 EN 953 EN 13857 EN 349	The guards are strong and built according to the rules.	Possible crushing		
1.4.2	Special requirements for guards	EN ISO 12100 EN 953 EN 13857 EN 349				
1.4.2.1	Fixed guards	EN ISO 12100 EN 953 EN 13857 EN 349	The fixing systems are suited to the type of guard.	Possible crushing		
1.4.3	Special requirements for protective devices	EN ISO 12100 EN 14238	The controls are mostly bimanual and compel the operator to keep both hands on the handgrips.			
1.5.1	Electricity supply	EN ISO 12100 EN 14238	The machine does not have electrical components.			
1.5.2	Static electricity	EN ISO 12100 EN 14238	The machine does not have risks of static electricity.			
1.5.3	Energy supply other than electricity	EN ISO 12100 EN 14238	The pneumatic system of the machine has been designed and built in conformity with the rules in force.			
1.5.4	Errors of fitting	EN ISO 12100	The machine installation is carried out by Dalmecc personnel expressly trained.			
1.5.5	Extreme temperatures	EN ISO 12100	The machine does not have risks of extreme temperatures.			
1.5.6	Fire	EN ISO 12100	The machine does not have risks of fire.			

Code	Requirements	Applied rules	Adopted solutions	Residual risk	Pictograms	
					Manual	Manipulator
1.5.7	Explosion	EN ISO 12100	The machine does not have risks of explosion.			
1.5.8	Noise	EN ISO 12100 EN 14238	The possible solutions are taken in order to reduce to the minimal level the emission of aerial noise.			
1.5.9	Vibrations	EN ISO 12100 EN 14238	The possible solutions are taken in order to reduce to the minimal level the vibrations.			
1.5.11	External radiation	EN ISO 12100	The use of material in conformity with the rules in force avoids the risk of external radiation.			
1.5.13	Emissions of hazardous materials and substances	EN ISO 12100	During the operation, the machine exhausts only compressed-air in the atmosphere.			
1.5.15	Risks of slipping, tripping or falling	EN ISO 12100 EN 14238	During the normal operation of the machine, there is no risk of falling. To carry out the regulation/servicing operations on non-reachable parts from floor, it is compulsory to use lifting equipment which follow the rules in force on safety in the installation place. It is absolutely forbidden to put lifting devices (ex. ladder) against the machine.			
1.6.1	Machinery maintenance	EN ISO 12100 EN 14238	The maintenance on the machine must be carried out by qualified personnel, following the indications in the Instruction Manual.			
1.6.2	Access to operating positions and servicing points	EN ISO 12100 EN 14238	To carry out the regulation/servicing operations on non-reachable parts from floor, it is compulsory to use lifting equipment which follow the rules in force on safety in the installation place. It is absolutely forbidden to put lifting devices (ex. ladder) against the machine.			
1.6.3	Isolation of energy sources	EN ISO 12100 EN 14238	Set prior to the machine an interception valve to isolate it from the energy source.			
1.6.4	Operator intervention	EN ISO 12100 EN 14238	The machine and its components are dimensioned to guarantee a working continuity which limits the intervention of the operator.			
1.6.5	Cleaning of internal parts	EN ISO 12100 EN 14238	Bring the machine in the parking position as described in the Instruction Manual. Disconnect the supply.			
1.7.1	Information and warnings on the machinery	EN ISO 12100 EN 14238	On the Manipulator several pictograms have been placed to identify residual dangers.			
1.7.1.1	Information and information devices	EN ISO 12100 EN 14238	In the Instruction manual all the necessary information are also provided for the use of the machine.			
1.7.2	Warning of residual risks	EN ISO 12100 EN 14238	Some warnings have been positioned on the machine to advice the operator about residual risks.			
1.7.3	Marking of machinery	EN ISO 12100 EN 14238	A plate with the identification data have been positioned on the machine. The Declaration of Conformity has been enclosed to this Manual.			
1.7.4	Instructions	EN ISO 12100 EN 14238	In order to use the machine in a correct way, an instruction and maintenance Manual has been arranged and the operator correctly informed.			

Code	Requirements	Applied rules	Adopted solutions	Residual risk	Pictograms	
					Manual	Manipulator
1.7.4.1	General principles for the drafting of instructions	EN ISO 12100 EN 14238	The instructions are arranged in the official languages of the Community.			
1.7.4.2	Contents of instructions	EN ISO 12100 EN 14238	The Instruction Manual contains all the necessary information for a correct use of the machine.			
1.7.4.3	Sales literature	EN ISO 12100				
2.1.1	General	EN ISO 12100 EN 14238	The machine is not designed to be used in environments for foods, cosmetics or pharmaceutical products.			
2.1.2	Instructions	EN ISO 12100 EN 14238	In the instruction manual we supply the warnings in case of washing of the machine.			
4.1.2.1	Risks due to lack of stability	EN ISO 12100 EN 14238	Together with the machine, we supply instructions for a correct use, transport and anchoring. The machine is equipped with stopping brakes or antidrift chain.			
4.1.2.2	Machinery running on guide rails on rail tracks	EN ISO 12100 EN 14238	The machine is equipped with an antiderailment device.			
4.1.2.3	Mechanical strength	EN ISO 12100 EN 14238	The dimensioning in conformity with the rules in force of all the machine parts, the choice of materials in relation to the use reduce to the minimum the risk of break during the working.			
4.1.2.4	Pulleys, drums, wheels, ropes and chains	EN ISO 12100 EN 14238	All the instructions about it are observed. The rope machines are equipped with double ropes.			
4.1.2.6	Control of movements	EN ISO 12100 EN 14238	The movements are obtained by control from the operator. The machine is equipped with speed decrease devices of the vertical drift in case of overbalancing of the load. Several angular delimiters have been installed on the rotations. The Manipulator is also equipped with the adjustment device of vertical end of stroke.			
4.1.2.7	Movements of loads during handling	EN ISO 12100 EN 14238	The equipment allows a wide view of the product in movement.			
4.1.3	Fitness for purpose	EN 14238	During the test, we check that the machine can work in safety condition.			
4.3.3	Lifting machinery	EN ISO 12100 EN 14238	The max weight capacity is indicated very clear, marked and indelible on the machines.			
4.4.2	Lifting machinery	EN ISO 12100 EN 14238	The instructions include the necessary information.			



6 Safety

This chapter describes the most important safety devices mounted on the Manipulator, how they work and how to be checked.

QUALIFICATION
3



6.1 SAFETY DEVICES

List of the safety devices, how they operate and how to check them. Check inspections intervals are listed at par. 7.2.

6.1.1 Non-return valve

Should the supply of compressed-air fail, the non-return valve prevents the reservoir from emptying.

◆ Check

- ⚠ Bring the Manipulator to the parking position
- Disconnect the compressed-air supply
- Check that there is no loss on the return valve

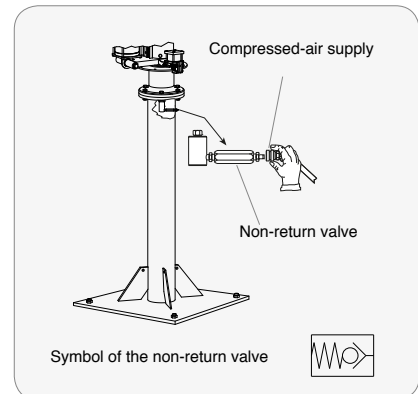

6.1.2 Safety valve

This device monitors the velocity of the arm's movement.

It is designed to prevent accidents occurring should the operator give the wrong command, for example: balancing before the load is gripped, or giving the release command before the load is on a firm surface.

◆ Check

- Moving the gripping tool up and down very quickly, you should notice a decreasing speed of the movement.

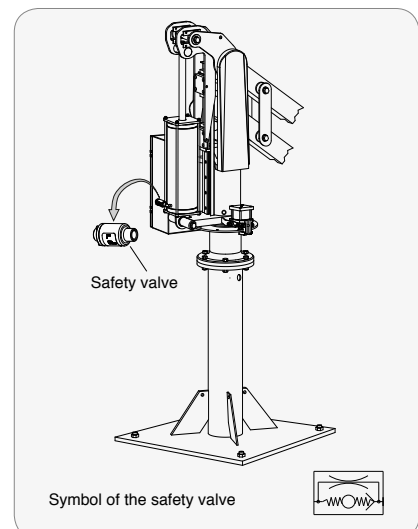

6.1.3 Pneumatic reservoir

It is an air reserve that allows the operator to position the load safely, in case of sudden compressed-air supply interruption.

◆ Check

No check is needed

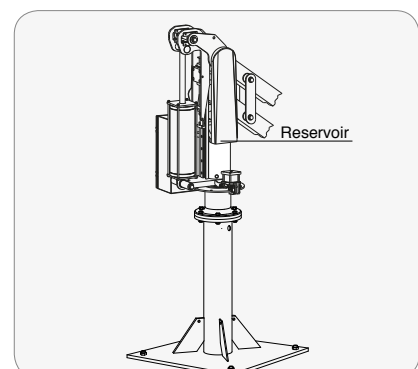

6.1.4 Anti-release

It prevents the tooling from releasing the load before it is correctly in place on a firm surface.

◆ **Check**



Before releasing the load, make sure that the operator will not be injured should the load fall

- Grip the lower weight load
- Position the load at 500 mm above the support point
- Give the release command and ensure that the tooling will not release the load before it is on a firm surface

During the release operation, avoid holding up the tooling with your hands.

- Should the Manipulator release the load before it is on a firm surface, urgently call Dalmecc Maintenance Service.

6.1.5 Piloted non-return valve

It prevents the releasing of the load in case of sudden compressed-air interruption.

◆ **Check**



Make sure that the operator will not be injured should the load fall

- Grip the load
- Bring the tooling to the minimum height
- Disconnect the supply
- Remove the air through the exhaust valve on the reservoir (see par.7)
- Check that the load is held until exhaust is completed.



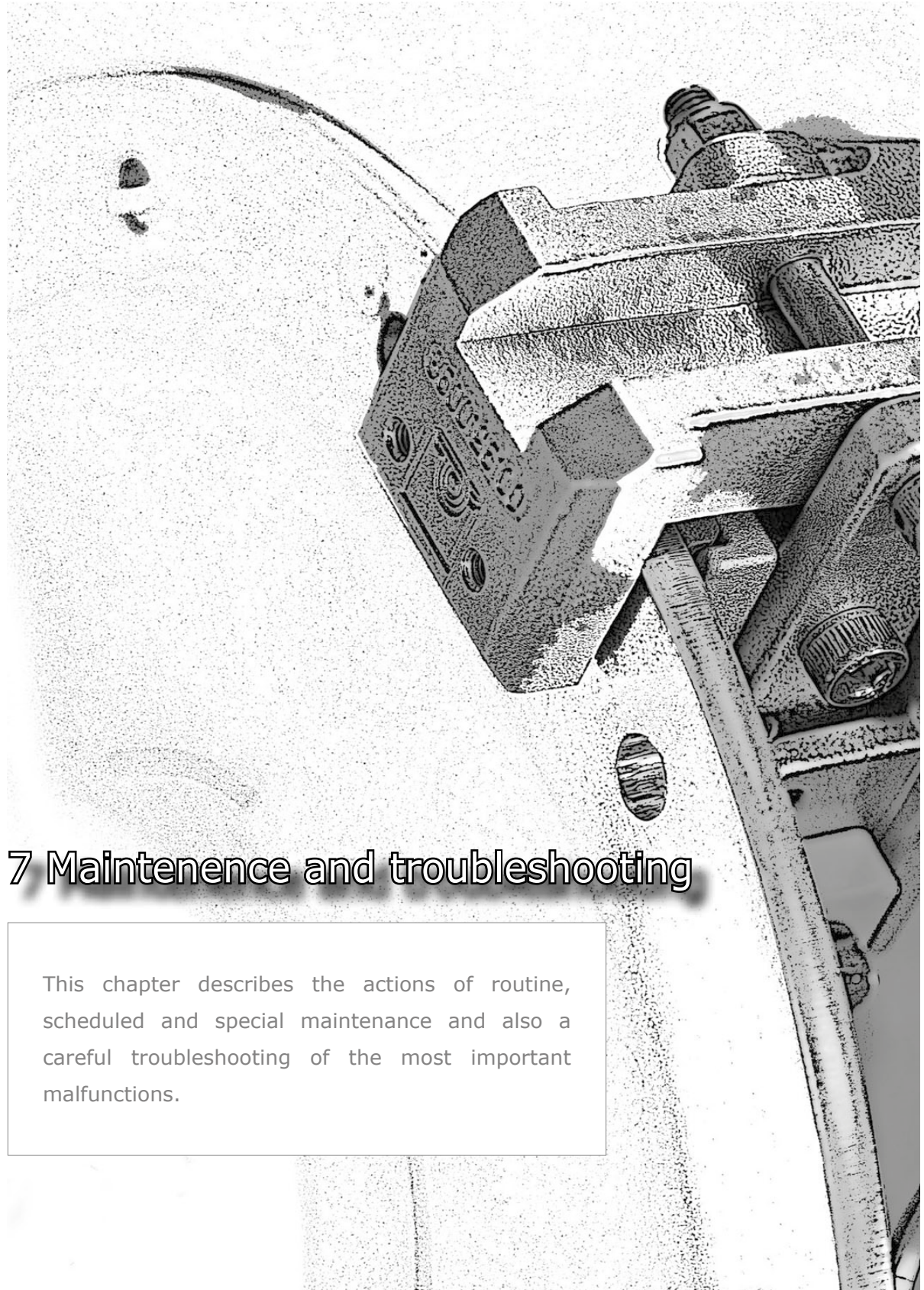

7 Maintenance and troubleshooting

This chapter describes the actions of routine, scheduled and special maintenance and also a careful troubleshooting of the most important malfunctions.

QUALIFICATION
3



7.1 ROUTINE MAINTENANCE

Remove the condensate from the reservoir

- Bring the Manipulator to the parking position
- Disconnect the air supply line
- Place a small container under the exhaust valve
- Turn the exhaust valve knob counterclockwise to remove the condensate from the reservoir
- When finished, turn the knob clockwise to close the exhaust valve
- Connect the supply line.

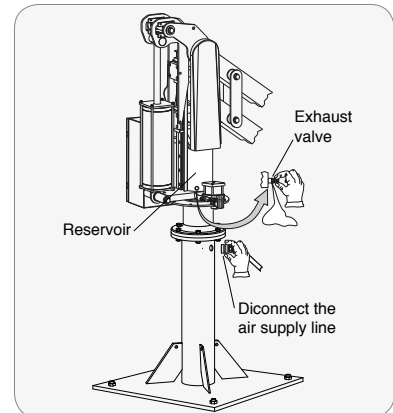

Cleaning of the silencers

- Clean the silencer on the pneumatic cylinder, on the relay and/or on the tooling by blowing in compressed-air.

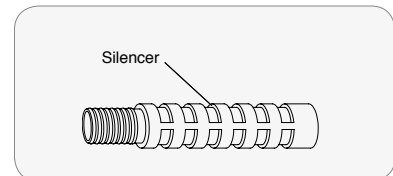

Check the brake system

- Check for wear and tear on the brake pads and, if necessary, replace them.
- Do not disconnect the compressed-air supply from the Manipulator's joints brakes.

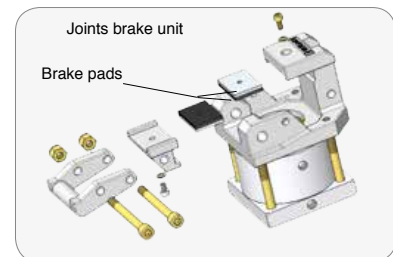

Check the pneumatic circuit

- Carry out a general check of the fittings and hose, checking that the connections are fastened tightly and that there is no air loss.

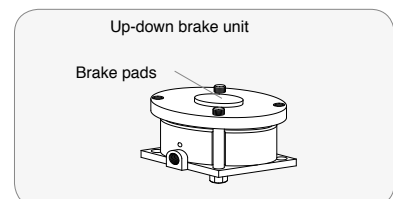

Check the gripping mandrel

- Check that the gripping dowels and the expanding cone are not worn and if necessary replace them.

() The numbering refers to the component reported in the pneumatic diagram (see par. 8.1)

Check the Manipulator bolts and screw

- With a torque wrench check the bolts and screws of the Manipulator and of the gripping tooling, verifying that the tightening torques are as listed below:

Resistance class 8.8 in conformity with UNI-3740			
Nominal diameter	Tightening torque in Nm	Nominal diameter	Tightening torque in Nm
M6	10	M18	290
M8	25	M20	410
M10	50	M22	560
M12	85	M24	710
M14	140	M27	1050
M16	210	M30	1420

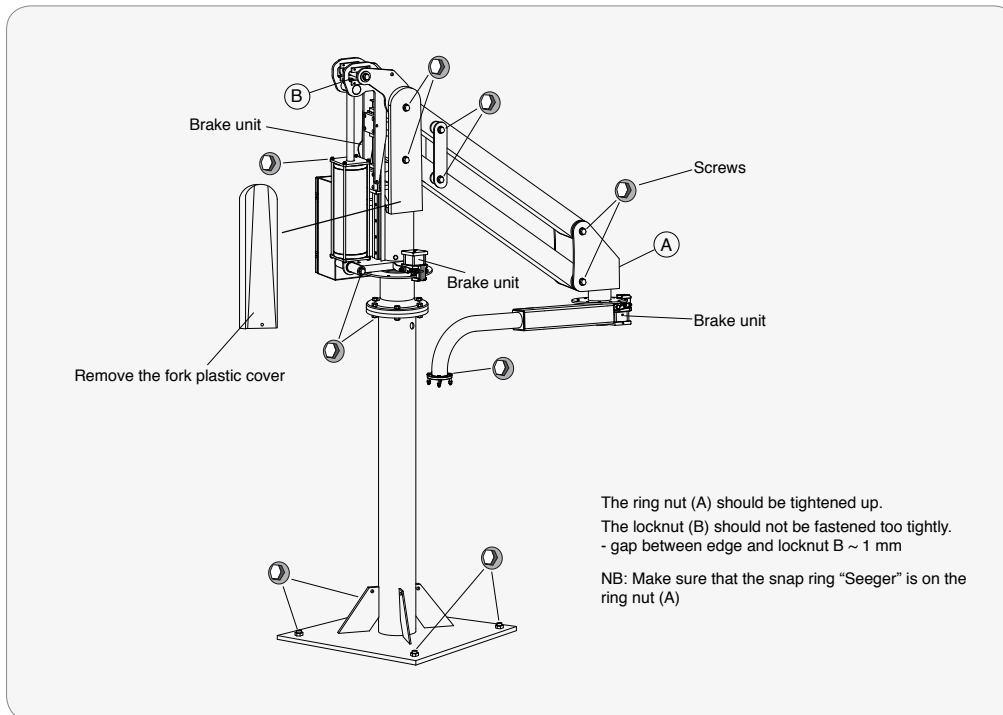

() The numbering refers to the component reported in the pneumatic diagram (see par. 8.1)

- If the Manipulator is fixed to the floor by fasteners, refer to the tightening torque recommended by the manufacturer.



7.2 SCHEDULED MAINTENANCE

A suitable planned maintenance schedule is a prerequisite requirement for safety, Manipulator life and correct operating. For this reason we recommend a list of controls and actions to be carried out only by maintenance staff.

Safety devices check	Every 50.000 working cycles	Every 150.000 working cycles	Every 300.000 working cycles
Non-return valve	*		
Safety valve		*	
Anti-release valve	*		
Piloted non-return valve		*	
Pressure limiter	*		
Bimanual control		*	
Stop valve	*		
Lock device	*		
Double vacuum circuit		*	
Sound device			*
Closing device	*		
Anti-fall device in case of electric power loss	*		

• For the type of device mounted and how to check it, please refer to chap. 6

Routine servicing	Every 50.000 working cycles	Every 150.000 working cycles
Check that bolts and screws of the Manipulator, of the gripping tooling and of the possible suspension system and motorization are tightly fastened	*	
Remove the condensate from the pneumatic reservoir using the special tap	*	
Cleaning of the silencers (if the manipulator working environment is dusty, servicing intervals should be shorter)		*
Check the brake system		*
Carry out a general check of the fittings and hose, checking that the connections are fastened tightly and that there is no air loss	*	
Check the gripping mandrel	*	

() The numbering refers to the component reported in the pneumatic diagram (see par. 8.1)

- In case of replacement of spare parts important for health and safety it is necessary to use Dalmecc original spares. For the part specifications refer to the list of the pneumatic components (see par. 8.2).
- When ordering spare parts, please refer always to the Manipulator serial number.
- Should replacement prove difficult, please call Dalmecc Maintenance Service or Dalmecc authorized technicians.

7.3 SPECIAL MAINTENANCE

QUALIFICATION
3

Balancing cylinder overhaul

Replace the balancing cylinder seals, and lubricate the cylinder inside barrel and its seal applying a trace of oil.

Oil type: POLYMER 400/000 with Liquilon
(Dalmec code 36.01.0025)
Quantity : 5cc

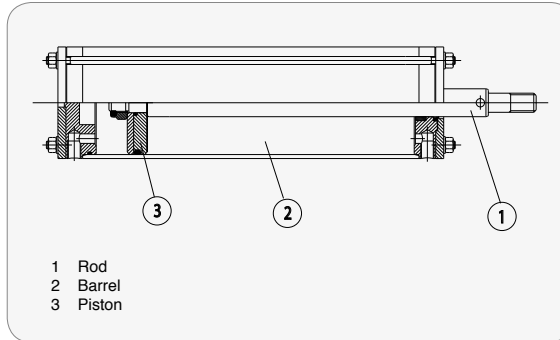

Rotating joint overhaul

Replace the rotating joint seals, and lubricate the centre shaft and its seal applying a trace of oil.

Oil type: POLYMER 400/000 with Liquilon
(Dalmec code 36.01.0025)
Quantity : 5cc

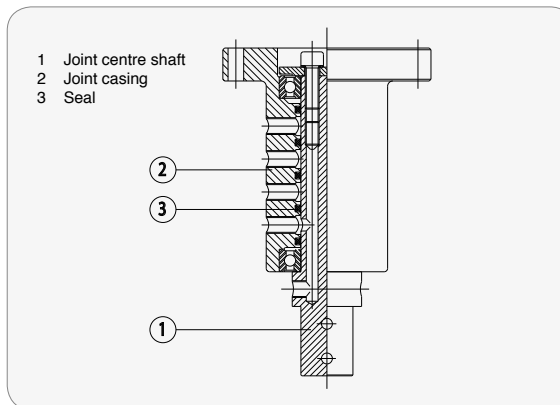

() The numbering refers to the component reported in the pneumatic diagram (see par. 8.1)

- When ordering spare parts, please refer always to the Manipulator serial number.

QUALIFICATION
3



7.4 TROUBLESHOOTING

List of the main problems causing the Manipulator to malfunction, why they occur and the actions to be taken. If your problems are other than the ones listed herein, call Dalmecc Maintenance Service or Dalmecc Authorized Technicians.

Problem - Main causes	Intervention	Ref. pneumatic diagram
The Manipulator does not balance without load		
The supply pressure is lower than required	<i>Adjust the supply pressure through the regulator-filter-group</i>	12
The regulator-filter group is broken	<i>Replace the regulator-filter group</i>	12
The no-load balancing is not well adjusted	<i>Adjust the no-load balancing regulator</i>	11
The no-load balancing regulator is broken	<i>Replace the no-load balancing regulator</i>	11
The non-return valve is inefficient	<i>Clean or replace the valve</i>	22
Sensible loss from the pneumatic cylinder	<i>Replace the seals on the balancing cylinder</i>	4
The silencer positioned on the relay is inefficient	<i>Check the silencer and, if necessary, replace it</i>	6
The pneumatic relay is inefficient	<i>Check the relay</i>	9
Loss from the pneumatic circuit	<i>Replace the leaky fittings or hose</i>	
The pressure selector is inefficient	<i>Replace the selector</i>	8
The Manipulator does not balance with load		
The supply pressure is lower than required	<i>Adjust the supply pressure through the regulator-filter-group</i>	12
The regulator-filter group is broken	<i>Replace the regulator-filter group</i>	12
The load balancing is not well adjusted	<i>Adjust the load balancing regulator</i>	46
The load balancing regulator is broken	<i>Replace the load balancing regulator</i>	46
The non-return valve is inefficient	<i>Clean or replace the valve</i>	22
Sensible loss from the pneumatic cylinder	<i>Replace the seals on the balancing cylinder</i>	4
The silencer positioned on the relay is inefficient	<i>Check the silencer and, if necessary, replace it</i>	6
The pneumatic relay is inefficient	<i>Check the relay</i>	9
Loss from the pneumatic circuit	<i>Replace the leaky fittings or hose</i>	
The pressure selector is inefficient	<i>Replace the selector</i>	8
The Manipulator does not grip the load		
The gripping control is inefficient	<i>Check - replace the pushbutton or the valve 3/2 way</i>	26-27-33-34
Pipes clogged - crushed near the controls	<i>Get the pipes free from the clogging - crushing</i>	
The impulse valve is inefficient	<i>Replace the valve</i>	48
The pressure regulator is inefficient	<i>Replace the regulator</i>	24
The flow regulator is out-of-adjustment - inefficient	<i>Adjust - replace the flow regulator</i>	49
The pressure threshold sensor is inefficient	<i>Replace the sensor</i>	56
The Manipulator does not release the load		
The release control is inefficient	<i>Check - replace the pushbutton or the 3/2 way valve</i>	36-37-43-44
Pipes clogged - crushed near the controls	<i>Get the pipes free from the clogging - crushing</i>	
The impulse valve is inefficient	<i>Replace the valve</i>	48
The piloted non-return valve is inefficient	<i>Replace the valve</i>	67
The timer is out-of-adjustment - inefficient	<i>Adjust - replace the timer</i>	50

() The numbering refers to the component reported in the pneumatic diagram (see par. 8.1)

7 MAINTENANCE AND TROUBLESHOOTING

The monostable valve is inefficient	<i>Replace the valve</i>	7
The 3/2 way amplifier valve is inefficient	<i>Replace the valve</i>	1
The Manipulator releases the load before it is correctly in position		
The timer is out-of-adjustment - inefficient	<i>Adjust - replace the timer</i>	50
The monostable valve is inefficient	<i>Replace the valve</i>	7
The 3/2 way amplifier valve is inefficient	<i>Replace the valve</i>	1
The Manipulator does not tilt the load		
The lever is inefficient	<i>Replace the lever</i>	52-64
The valve is inefficient	<i>Replace the valve</i>	60
The flow regulator is out-of-adjustment - inefficient	<i>Adjust or replace the flow regulator</i>	58-59-61-62
The brake system does not operate		
The brake lever is inefficient	<i>Replace the lever</i>	25
The distance between pads and brake disk is out-of-adjustment or the pads are worn.	<i>Adjust the distance between the pads and the brake disk, as described in the manual, or replace the wear pads</i>	
The monostable valve is inefficient	<i>Replace the valve</i>	19



() The numbering refers to the component reported in the pneumatic diagram (see par. 8.1)

QUALIFICATION
3



7.4.1 Pneumatic relay

The pneumatic relay is the most important valve which enables the balancing of the equipment with or without load. Its abnormal working involves a bad working of the whole manipulator. The principal malfunctions are analyzed in the table below.

Pneumatic relay

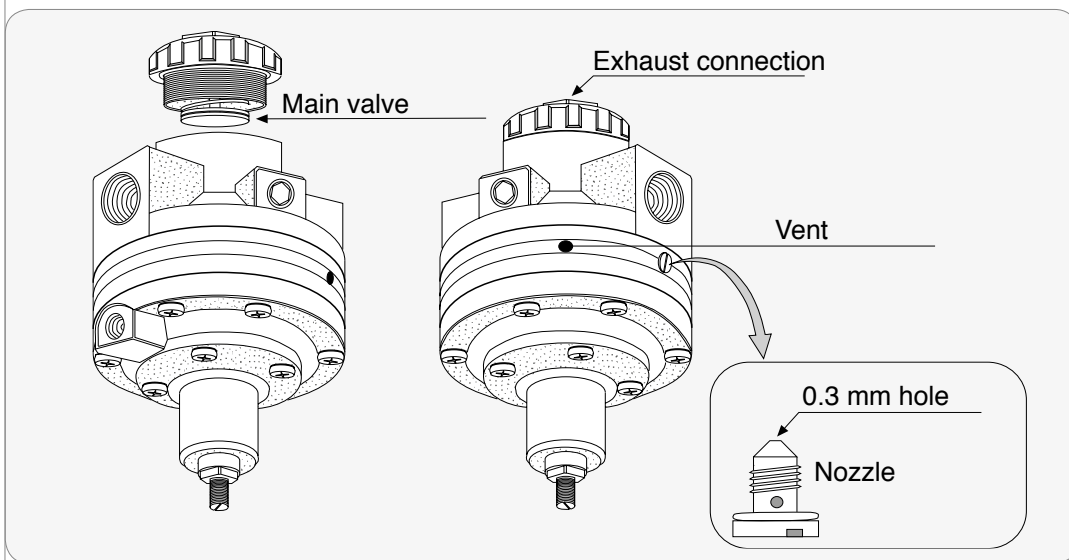

Problem	Check	Cause	Action
The exhaust pressure can not be adjusted.	No air passing through the vent.	The nozzle is clogged.	Remove the nozzle and clean the 0.3 mm hole using a very thin copper wire or a needle and then blow in compressed-air. If the nozzle can not be fully cleaned, replace it with a new one. If not available, use the regulator with the nozzle slightly loosened.
	The exhaust pressure can be adjusted loosening the nozzle.		
Too much air comes out of the exhaust connection.	There is a loss over 2 NL/min although there is no exhaust due to back pressure.	Too much dust in the seat of the main valve or in the exhaust valve.	Remove the valve from its holder and clean its seat.
		The seat of one of these valves is damaged.	Replace the relay.
		Irregular contact of the exhaust valve.	
The exhaust pressure is unstable.	The exhaust pressure settles by loosening the nozzle.	The nozzle has been blocked beyond the limit.	Remove the nozzle and clean the 0.3 mm hole using a very thin copper wire or a needle and then blow in compressed-air. If the nozzle can not be fully cleaned, replace it with a new one.

() The numbering refers to the component reported in the pneumatic diagram (see par. 8.1)

7.5 CHECK REGISTERS

QUALIFICATION
3



Register of scheduled and special maintenance actions

Manipulator serial No.	Check executor	Date		
Safety devices check	✓ For the type of device mounted and how to check it, please refer to chap. 6	Efficiency		Malfunctions noticed - comments
		YES	NO	
	Non-return valve			
	Safety valve			
	Anti-release valve			
	Piloted non-return valve			
	Pressure limiter			
	Bimanual control			
	Stop valve			
	Lock device			
	Double vacuum circuit			
	Sound device			
	Closing device			
Anti-fall device in case of electric power loss				
Routine actions	✓ For the routine maintenance instructions see par 7.1	Carried out		Malfunctions noticed - comments
		YES	NO	
	Removal of the condensate			
	Clean the silencers			
	Check the brake system			
	Check the pneumatic system			
	Check that bolts and screws of the manipulator and of the possible suspension system are tightly fastened			
	Check the shelters or the protective devices			
	Check of the gripping suction cups			
	Check the covering of the gripping jaws			
	Check the load presence sensor			
	Check the gripping mandrel			
	Cleaning of vacuum filter			
	Check of the gripping references			
	Check of the gripping jaws kinematic motion			
	Cleaning of drum filter			
	Cleaning of bag filter			
	Check the booster			
	Check the oil in the reducer and in the motorization's lubricator			
	Check the rack-pinion assembly			
Check the ropes and pulleys				
Check the earth bonding				
Cleaning of the Manipulator				
Cleaning of the magnet				
Special actions	✓ For the maintenance instructions see par 7.3	Carried out		Malfunctions noticed - comments
		YES	NO	
	Balancing cylinder overhaul			
	Rotating joint overhaul			
Replacement of the rope				
General actions	Presence of the identification plate			
	Identification of controls			
	Quality and cleanliness of the air supply			
	Electric supply line (where it is present)			
	Electric harness (where it is present)			

() The numbering refers to the component reported in the pneumatic diagram (see par. 8.1)

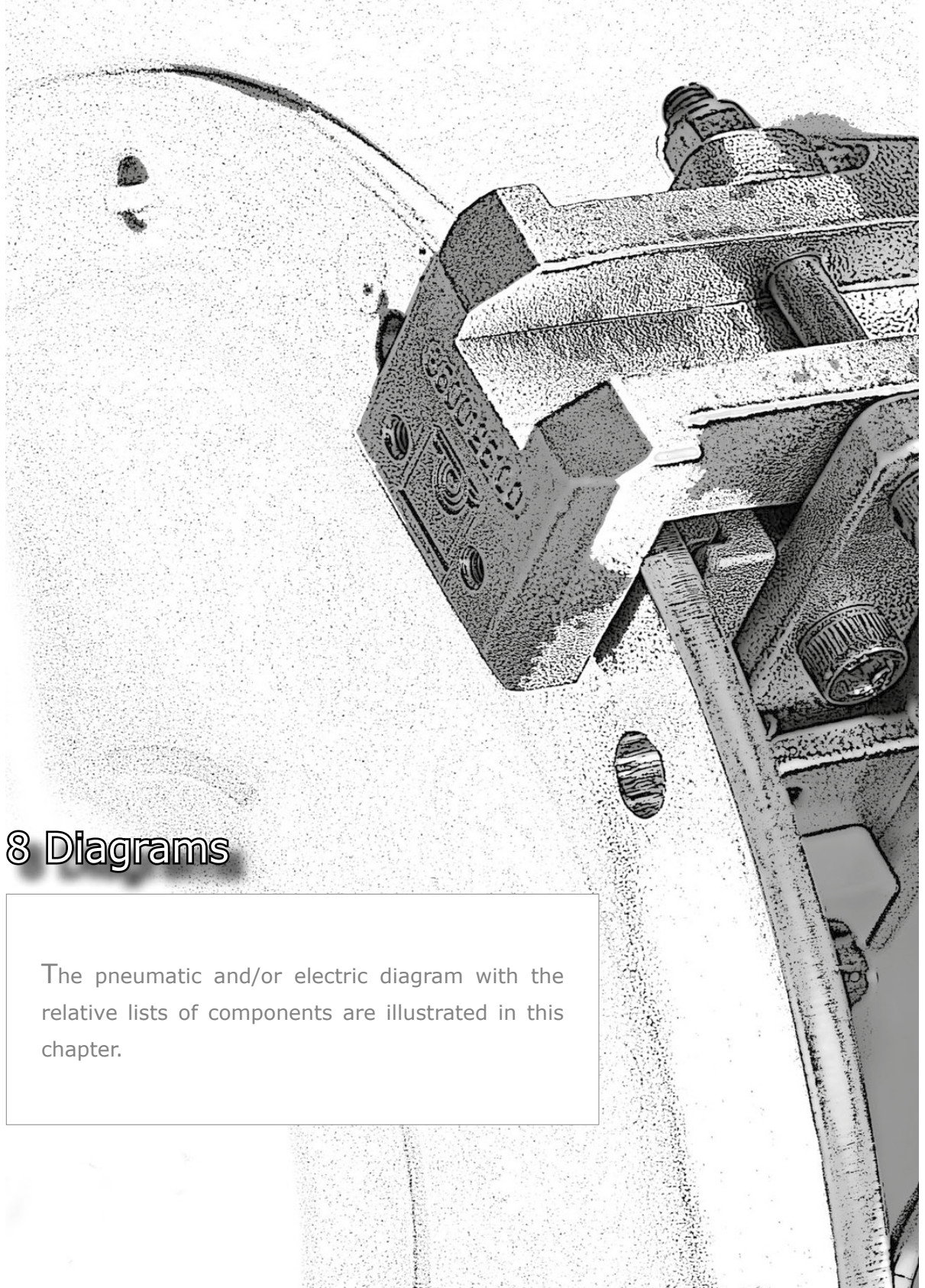

8 Diagrams

The pneumatic and/or electric diagram with the relative lists of components are illustrated in this chapter.

8.1 PNEUMATIC DIAGRAM

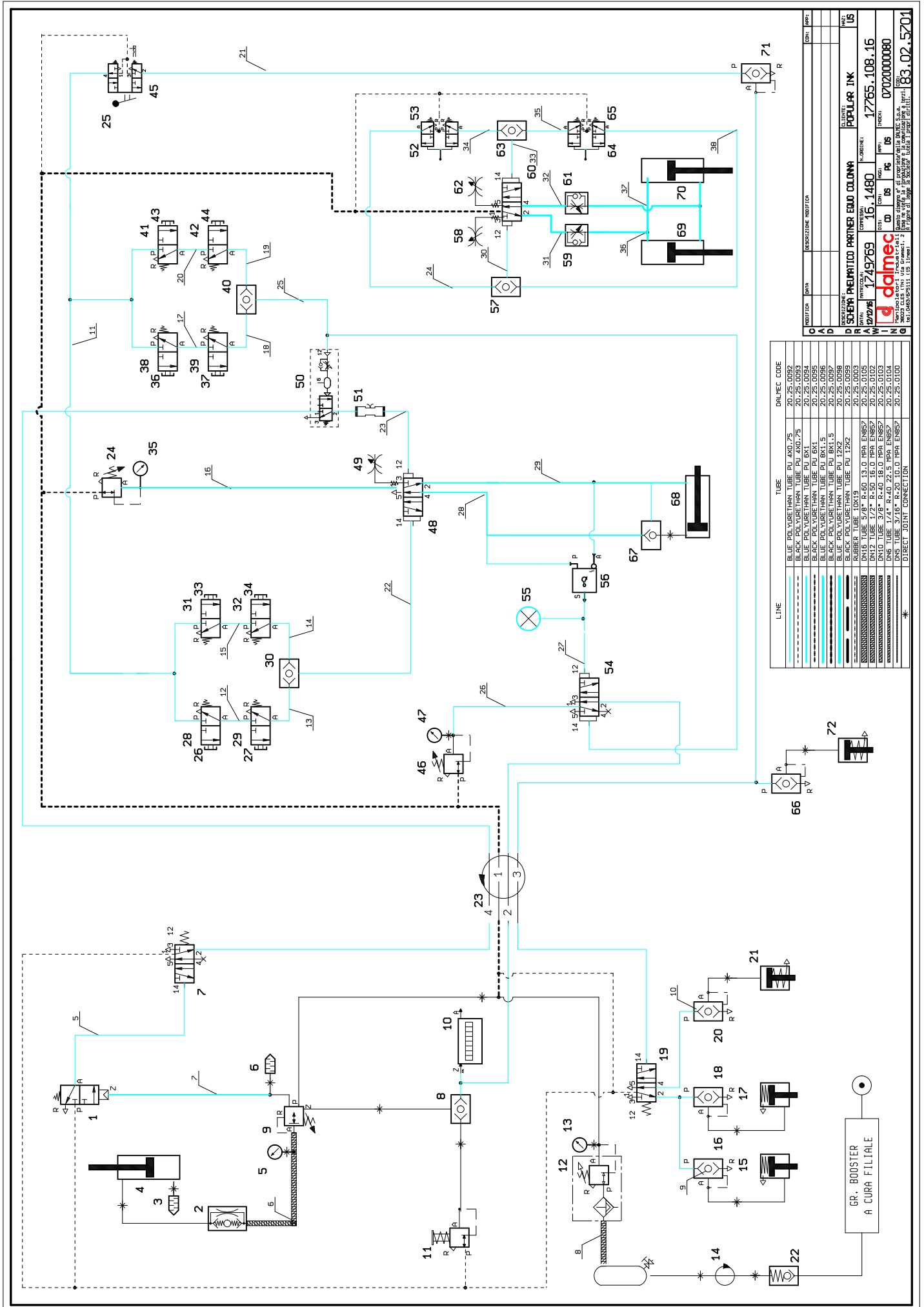

LINE	TUBE	DALMEC CODE
1	BLUE POLYURETHAN TUBE PU 4X0,75	20.25.0052
2	BLACK POLYURETHAN TUBE PU 6X1	20.25.0054
3	BLACK POLYURETHAN TUBE PU 8X1,5	20.25.0095
4	BLACK POLYURETHAN TUBE PU 8X1,5	20.25.0095
5	BLACK POLYURETHAN TUBE PU 12X2	20.25.0059
6	RUBBER TUBE 10X19	20.25.0003
7	DN16 TUBE 5/8" R-60 13.0 MPA EN857	20.25.0105
8	DN12 TUBE 1/2" R-50 16.0 MPA EN857	20.25.0102
9	DN8 TUBE 1/4" R-40 22.5 MPA EN857	20.25.0104
10	DN8 TUBE 3/16" R-20 10.0 MPA EN857	20.25.0100
11	DIRECT JOINT CONNECTION	*

DESCRIZIONE	DATA	DESCRIZIONE MODIFICAZIONE	CON. MOD.
CLIENTE	POPULAR INK		US
MODELLO	1743769		
NUMERO	16.1480		
PRODOTTORE	dalmecc		
NUMERO	1765.108.16		
NUMERO	0702000080		
NUMERO	83.02.5701		

8.2 LIST OF THE PNEUMATIC COMPONENTS

Ref.	Qty	Description	Dalmecc code	Producer	Producer code
1	1	3/2 way 1/8" amplifier valve nc	20.22.0138	DALMEC	2LA-AM
2	1	Safety valve 3	00.79.0025	DALMEC	00.79.0025
3	1	Silencer 3/8" M model AN	20.17.0024	SMC	AN30-03
4	1	Balancing cylinder D150 double acting conn. 45	00.08.0506	DALMEC	00.08.0506
5	1	Pressure gauge D40 1/4"G 0>1 MPa / 0>145 psi	00.79.0095	DALMEC	00.79.0095
6	1	Silencer 3/8" M model AN	20.17.0024	SMC	AN30-03
7	1	Base D4 + monostable valve P10.5	00.79.0460	DALMEC	00.79.0460
8	1	Selector OR 1/4"	00.79.0308	DALMEC	00.79.0308
9	1	Pneumatic relay 1/2" G - piloted	00.79.0510	DALMEC	00.79.0510
10	1	Impulse counter 8 figures without reset	00.79.0381	DALMEC	00.79.0381
11	1	Precision regulator 1/4" 0>0.6 MPA	20.27.0037	SMC	ARP20K-F02-3
12	1	Filter regulator 1/2"	00.79.0311	DALMEC	00.79.0311
13	1	Pressure gauge D50 1/4"G 0>1 MPa / 0>145 psi	00.79.0148	DALMEC	00.79.0148
14	1	1-way 3/8" joint G- M-16x1.5	00.52.0063	DALMEC	00.52.0063
15	1	Brake ass. with locating plate	00.97.0387	DALMEC	00.97.0387
16	1	Quick exhaust valve 1/8" F	20.28.0034	SMC	EAQ1510-F01
17	1	Brake ass. with locating plate	00.97.0387	DALMEC	00.97.0387
18	1	Quick exhaust valve 1/8" F	20.28.0034	SMC	EAQ1510-F01
19	1	Base D4 + monostable valve P10.5	00.79.0460	DALMEC	00.79.0460
20	1	Quick exhaust valve 1/8" F	20.28.0034	SMC	EAQ1510-F01
21	1	Cylinder D63 H10 type CSR-63-10	00.08.0161	DALMEC	00.08.0161
22	1	Non return valve 3/8" gas	00.79.0086	DALMEC	00.79.0086
23	1	4-way joint D50	00.52.0076	DALMEC	00.52.0076
24	1	Regulator without air outlet 1/4" G 0>0.8 MPa	00.79.0098	DALMEC	00.79.0098
25	1	Selector switch black long handle	00.79.0208	DALMEC	00.79.0208
26	1	Flush black pushbutton	00.79.0190	DALMEC	00.79.0190
27	1	Flush black pushbutton	00.79.0190	DALMEC	00.79.0190
28	1	3/2 way D4 panel-mounting valve NC	00.79.0219	DALMEC	00.79.0219
29	1	3/2 way D4 panel-mounting valve NC	00.79.0219	DALMEC	00.79.0219
30	1	Logic valve D4 OR	00.79.0175	DALMEC	00.79.0175
31	1	3/2 way D4 panel-mounting valve NC	00.79.0219	DALMEC	00.79.0219
32	1	3/2 way D4 panel-mounting valve NC	00.79.0219	DALMEC	00.79.0219
33	1	Flush black pushbutton	00.79.0190	DALMEC	00.79.0190
34	1	Flush black pushbutton	00.79.0190	DALMEC	00.79.0190
35	1	Pressure gauge D40 1/8"G 0>1 MPa / 0>145 psi	00.79.0084	DALMEC	00.79.0084
36	1	Flush red pushbutton	00.79.0191	DALMEC	00.79.0191
37	1	Flush red pushbutton	00.79.0191	DALMEC	00.79.0191
38	1	3/2 way D4 panel-mounting valve NC	00.79.0219	DALMEC	00.79.0219
39	1	3/2 way D4 panel-mounting valve NC	00.79.0219	DALMEC	00.79.0219
40	1	Logic valve D4 OR	00.79.0175	DALMEC	00.79.0175
41	1	3/2 way D4 panel-mounting valve NC	00.79.0219	DALMEC	00.79.0219
42	1	3/2 way D4 panel-mounting valve NC	00.79.0219	DALMEC	00.79.0219
43	1	Flush red pushbutton	00.79.0191	DALMEC	00.79.0191
44	1	Flush red pushbutton	00.79.0191	DALMEC	00.79.0191
45	1	5/2 way D4 panel-mounting valve NO+NC	00.79.0221	DALMEC	00.79.0221
46	1	Pre-selector Dalmecc disc D100	00.79.0151	DALMEC	00.79.0151
47	1	Pressure gauge D40 1/8"G 0>1 MPa / 0>145 psi	00.79.0084	DALMEC	00.79.0084
48	1	Base D8 + preferential bistable valve P10.5	00.79.0471	DALMEC	00.79.0471
49	1	Flow regulator D8	00.79.0161	DALMEC	00.79.0161
50	1	Adjustable timer 0>5" NC D4	00.79.0480	DALMEC	00.79.0480
51	1	One touch straight fitting tubes D4 with air outlet	20.07.0425	DALMEC	20.07.0425
52	1	3-position joystick lever	00.79.0228	DALMEC	00.79.0228

8 DIAGRAMS

53	1	5/3 way valve D4 panel-mounting NC	00.79.0222	DALMEC	00.79.0222
54	1	Base D4 + preferential bistable valve P10.5	00.79.0461	DALMEC	00.79.0461
55	1	Optical indicator PXV D22 green	20.18.0006	PARKER P.	PXV-F131
56	1	Pressure threshold sensor with sub-base	20.28.0085	PARKER P.	PLN-D12
57	1	Logic valve D4 OR	00.79.0175	DALMEC	00.79.0175
58	1	Flow regulator D8	00.79.0161	DALMEC	00.79.0161
59	1	Flow regulator one touch fitting D8	20.28.0011	SMC	AS2052F-08
60	1	Base D8 + preferential bistable valve P10.5	00.79.0471	DALMEC	00.79.0471
61	1	Flow regulator one touch fitting D8	20.28.0011	SMC	AS2052F-08
62	1	Flow regulator D8	00.79.0161	DALMEC	00.79.0161
63	1	Logic valve D4 OR	00.79.0175	DALMEC	00.79.0175
64	1	3-position joystick lever	00.79.0228	DALMEC	00.79.0228
65	1	5/3 way valve D4 panel-mounting NC	00.79.0222	DALMEC	00.79.0222
66	1	Quick exhaust valve 1/8" F	20.28.0034	SMC	EAQ1510-F01
67	1	Unidirectional stop valve 1/8" D4	20.22.0133	CAMOZZI	VBU 1/8
68	1	Cylinder D 150 H 39 double acting	P0.97.0192	DALMEC	Position C1
69	1	Cylinder DSBC-100-125-PPVA-N3	20.14.0311	FESTO	1384809
70	1	Cylinder DSBC-100-125-PPVA-N3	20.14.0311	FESTO	1384809
71	1	Quick exhaust valve one touch fitting D4	20.28.0032	SMC	AQ240F-04-00
72	1	Cylinder D40 H10 type CSR-40-10	00.08.0250	DALMEC	00.08.0250

EC Declaration of Conformity

(Ann. IIA DIR. 2006/42/EC)

DALMEC S.p.A.

Via Gramsci, 2
38023 CLES (Trento) - Italy

HEREBY DECLARES THAT THE MACHINE

Description	Industrial Manipulator Partner equo
Type	PEC
Serial No.	1749769
Construction year	2017
Commercial denomination	Partner equo

COMPLIES WITH

Directive 2006/42/EC of the European Parliament and the Council of 17th May 2006 on machinery.

Reference of harmonised standards: EN 12100, EN 14238

AND AUTHORIZES

Dallago Christian
Via Gramsci, 2
38023 CLES (Trento) - Italy

TO CONSTITUTE THE TECHNICAL FILE

Name Luciano Dallago
Position General Director

Signature

Place and date of issue
Cles 28/02/2017

